

THRUSH® PERFORMANCE EXHAUST PRODUCTS

Classic Performance Sound at an Affordable Price

Thrush performance exhaust products are designed to make hot rods hotter, offering vintage sound and today's power



Thrush® Turbo Exhaust System



Thrush introduces the first full Thrush Turbo exhaust systems for popular classic hot rods

2-1/2" smooth-bend full-aluminized tubing

Includes H-pipe and two classic Thrush Turbo mufflers

Includes all necessary hangers, brackets and other hardware

Thrush Turbo exhaust systems are a perfect match for DynoMax® Blackjack® and Cyclone® headers

History, horsepower and unbeatable value – that's the Thrush advantage

Thrush® Welded Muffler



100% Aluminized and fully welded for extended durability and wear

Two-chamber design for improved flow and deep, aggressive tone

Available in a 19" overall length

2-1/4", 2-1/2" or 3" inlet and outlet

Available aluminized or polished stainless steel

Thrush® Turbo Muffler



100% Aluminized cover for long life

Unique, high-flow design with reversible flow chambers

Expandable bushings for custom applications

Time-proven spun-locked heads for leak-free seal

Classic turbo muffler design

All mufflers are reversible for maximum flexibility

Thrush® Glasspack Muffler



Heavy-gauge shell for maximum durability

Expandable bushings for custom applications

CRF (Continuous Roving Fiberglass) for powerful tone and long life

Straight-through design for maximum flow and power

Available painted or stainless steel

Dual outlet model available – great for pick-up trucks and custom applications!



THRUSH® EXHAUST PRODUCTS

What better way to complete a classic hot rod than with a classic exhaust system? Thrush is proud to announce the availability of complete header back exhaust systems for popular muscle cars and trucks. Most systems feature 2½" aluminized, smooth bent pipe, H-pipe balance tubes, and classic Thrush Turbo mufflers. The systems are a perfect match for DynoMax Blackjack and Cyclone headers. History, horsepower, and an unbeatable value, that's the Thrush advantage.



Thrush®

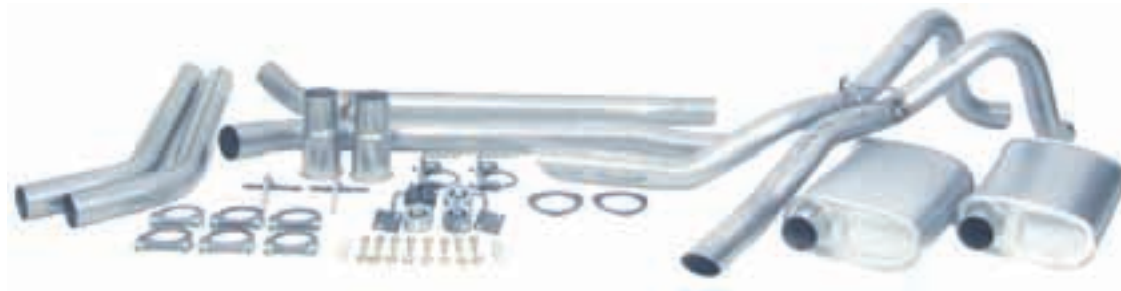

THRUSH® DUAL KIT APPLICATIONS

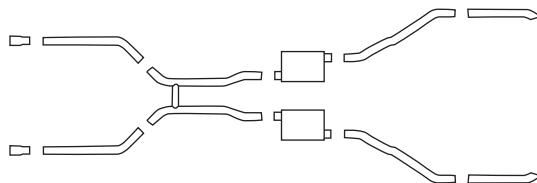

Vehicle Application	Year	Engine	Dual Kit	Used w/Header	Footnotes
CARS			Blackjack/ Cyclone		
GENERAL MOTORS CORPORATION					
BUICK					
Skylark	72-64	265-400CH	89023	85001/86001	
Skylark	72-64	396-454CH	89023	85110/86110	
CHEVROLET					
Camaro (Exc. Convertible)	74-67	265-400	89021	85001/86001	Duals w/single transverse muffler
Camaro (Exc. Convertible)	74-67	396-454	89021	85110/86110	Duals w/single transverse muffler
Camaro	73-70	265-400	89020	85001/86001	
Camaro	73-70	396-454	89020	85110/86110	
Camaro (Exc. Convertible)	69	265-400	89018	85001/86001	
Camaro (Exc. Convertible)	68-67	265-400	89022	85001/86001	
Chevelle	72-64	265-400	89023	85001/86001	
Chevelle	72-64	396-454	89023	85011/86110	
El Camino	72-64	265-400	89019	85001/86001	
El Camino	72-68	396-454	89019	85110/86110	
Malibu	67-64	265-400	89023	85001/86001	
Malibu	67-64	396-454	89023	85110/86110	
Monte Carlo	72-70	265-400	89023	85001/86001	
Monte Carlo	72-70	396-454	89023	85110/86110	

MUFFLERS

PASSENGER CAR SYSTEMS

TRUCK SYSTEMS

DUAL PIPE KITS / HEADERS

THRUSH

ACCESSORIES / UNIV. PIPE

DNX

THRUSH® DUAL KIT APPLICATIONS



Application	Year	Engine	Dual Kit	Used w/Header	Footnotes
CHEVROLET (Continued)					
Nova	74-67	265-400	89021	85001/86001	Duals w/single transverse muffler
Nova	74-67	396-454	89021	85110/86110	Duals w/single transverse muffler
Sprint (GMC)	72-71	265-400	89019	85001/86001	
Sprint (GMC)	72-71	396-454	89019	85110/86110	
DODGE					
Challenger	72-70	318-340	89026	85035/86035	
Challenger	72-70	383-440	89026	85034/86034	
FORD					
Mustang	70-67	289-302	89025	85124/86124	
Mustang	70-68	427-429	89025	N/A	
Mustang	70-69	351W	89025	85112	
Mustang	70	351C-2V	89025	85063	
Mustang	70	351C-4V	89025	85064	
Mustang	69-67	390	89025	N/A	
OLDSMOBILE					
Cutlass	72-65	350-455OL	89023	85029/86029	
Cutlass	72-64	265-400CH	89023	85001/86001	
Cutlass	72-64	396-454CH	89023	85110/86110	
PLYMOUTH					
Barracuda	72-70	318-340	89026	85035/86035	
Barracuda	72-70	383	89026	85034/86034	
PONTIAC					
Firebird (Exc. Convertible)	74-70	326-455PO	89021	85114/86114	Duals w/single transverse muffler
Firebird (Exc. Convertible)	74-67	265-400CH	89021	85001/86001	Duals w/single transverse muffler
Firebird (Exc. Convertible)	74-67	396-454CH	89021	85110/86110	Duals w/single transverse muffler
Firebird	73-70	265-400CH	89020	85001/86001	
Firebird	73-70	396-454CH	89020	85110/86110	
Firebird	73-70	326-455PO	89020	85114/86114	
Firebird (Exc. Convertible)	69	350-400PO	89018	85113	
Firebird (Exc. Convertible)	69	265-400CH	89018	85001/86001	
Firebird (Exc. Convertible)	68-67	326-400PO	89022	85113	
Firebird (Exc. Convertible)	68-67	265-400CH	89022	85001/86001	
GTO, LeMans, Tempest	72-64	265-400CH	89023	85001/86001	
GTO, LeMans, Tempest	72-64	396-454CH	89023	85110/86110	
TRUCKS					
CHEVROLET/GMC					
C-Series Pickup - 2WD					
1/2, 3/4 Ton Pickup	72-66	283-350	89027*	85003/86003	
1/2, 3/4 Ton Pickup	72-66	283-350	89027*	85503	Headers w/air injection fittings
1/2, 3/4 Ton Pickup	72-68	396-454	89027*	85022/86022	
K-Series Pickup - 4WD					
1/2, 3/4, 1 Ton Pickup	87-73	350-400	89024	85003/86003	
1/2, 3/4, 1 Ton Pickup	87-73	350-400	89024	85503	Headers w/air injection fittings
1/2, 3/4, 1 Ton Pickup	87-73	396-454	89024	85089/86089	

* - Fits w/rear coil springs only.

CH - Chevrolet
 OL - Oldsmobile
 PO - Pontiac

THRUSH® MUFFLERS



Classic Performance Sound at an Affordable Price

Quality-built and competitively priced, the Thrush line-up of unique mufflers and accessories are available to provide your car, light truck or SUV with an aftermarket exhaust system that delivers, mile after mile.

NEW!

Thrush® Welded Muffler



Fully welded for extended durability and wear

Two-chamber design for improved flow and deep, aggressive tone

Available in a 19" overall length

2-1/4", 2-1/2" or 3" inlet and outlet

Available in painted aluminized steel or type 304 stainless steel, buffed and polished

Thrush® Turbo Muffler



100% Aluminized cover for long life

Proven reverse-flow design

Expandable bushings for custom applications

Time-proven spun-locked heads for leak-free seal

All mufflers are reversible for maximum flexibility

Thrush® Glasspack Muffler



Heavy-gauge shell for maximum durability

Expandable bushings for custom applications

CRF (Continuous Roving Fiberglass) for powerful tone and long life

Straight-through design for maximum flow and power

Available painted or type 304 stainless steel





Dual outlet model available – great for pick-up trucks and custom applications!

THRUSH® WELDED MUFFLERS



NEW!



	Part Number	Shell Diameter	Overall Length	Shell Length	Inlet Diameter	Outlet Diameter
 <p>Side - Center</p>	17655	4 x 9½	19	13	2¼	2¼
	17656	4 x 9½	19	13	2½	2½
	17657	4 x 9½	19	13	3	3
	● 17648+	4¾ x 9⅝	19	13	2¼	2¼
	● 17647+	4¾ x 9⅝	19	13	2½	2½
	● 17646+	4¾ x 9⅝	19	13	3	3
 <p>Center - Side</p>	● 17651	4 x 9½	19	13	2¼	2¼
	● 17650	4 x 9½	19	13	2½	2½
	● 17649	4 x 9½	19	13	3	3
	● 17641+	4¾ x 9⅝	19	13	2¼	2¼
	● 17640+	4¾ x 9⅝	19	13	2½	2½
	● 17639+	4¾ x 9⅝	19	13	3	3
 <p>Side - Side</p>	17658	4 x 9½	19	13	2¼	2¼
	17659	4 x 9½	19	13	2½	2½
	17660	4 x 9½	19	13	3	3
	● 17645+	4¾ x 9⅝	19	13	2¼	2¼
	● 17644+	4¾ x 9⅝	19	13	2½	2½
	● 17643+	4¾ x 9⅝	19	13	3	3
 <p>Center - Dual Outlet</p>	● 17652	4 x 9½	19	13	2¼	2¼ (2)
	● 17653	4 x 9½	19	13	2½	2½ (2)
	17661	4 x 9½	19	13	3	2½ (2)
	● 17642+	4¾ x 9⅝	19	13	3	2½ (2)

- New Number
- + Type 304 stainless steel, buffed and polished

THRUSH® TURBO MUFFLERS



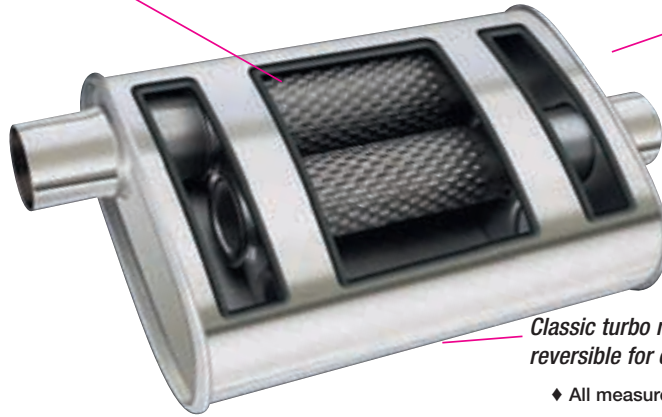

Aluminized cover for long life.

Time-proven spun-lock heads for leak-free seal.



Classic turbo muffler design ... All mufflers are reversible for custom installation

◆ All measurements are inside diameter, unless noted otherwise

	Part Number	Shell Diameter	Overall Length	Shell Length	Inlet Diameter◆	Outlet Diameter◆
 <p>Side - Center</p>	17700	3¼ x 7¾	16	11	1½	1½
	17702	3¼ x 7¾	16	11	2	2
	17704	3¼ x 7¾	18½	14	2	2
	17711	4¼ x 9¾	18½	14	2	2
	17713	4¼ x 9¾	18½	14	2¼	2¼
	17715	4¼ x 9¾	18½	14	2½	2½
	17716	4¼ x 9¾	25	20	2	2
	17717	4¼ x 9¾	25	20	2¼	2¼
	17718	4¼ x 9¾	25	20	2½	2½
 <p>Side - Side</p>	17703	3¼ x 7¾	16	11	2	2
	17705	3¼ x 7¾	18½	14	2	2
	17712	4¼ x 9¾	18½	14	2	2
	17714	4¼ x 9¾	18½	14	2¼	2¼
	17696	4¼ x 9¾	18½	14	2½	2½
 <p>Header Muffler</p>	17694	4¼ x 9¾	25½	14	3	2½
 <p>Dual Inlet / Outlet (Will flow all directions/connections)</p>	17654	4¼ x 9¾	24	20	2½ (2)	2½ (2)

MUFFLERS

PASSENGER CAR SYSTEMS

TRUCK SYSTEMS

DUAL PIPE KITS / HEADERS

THRUSH

ACCESSORIES / UNIV. PIPE

DNX

THRUSH® GLASSPACK MUFFLERS

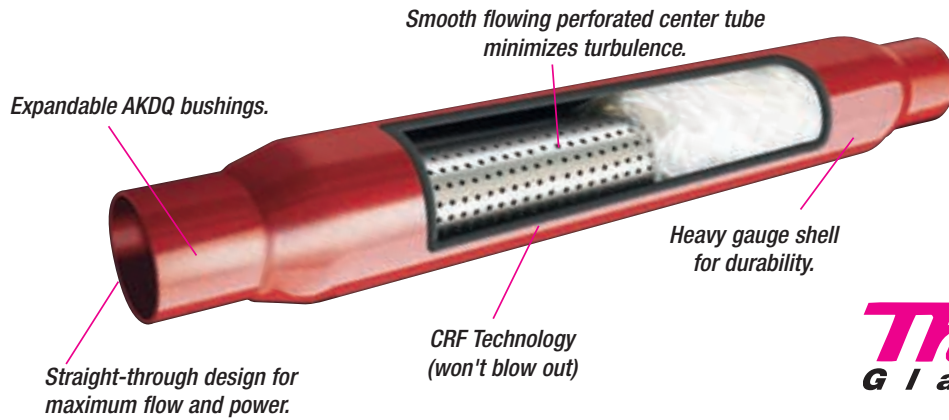

Single Outlet - Stainless Steel

Part No.	Overall Length	Shell Length	Inlet I.D.	Outlet I.D.	Tube Diameter	Body Diameter
24239	25	20	2¼	2¼	2¼	3½
24240	25	20	2½	2½	2½	3½
24241	25	20	3	3	3	4

Single Outlet - Powder Coated

Part No.	Overall Length	Shell Length	Inlet I.D.	Outlet I.D.	Tube Diameter	Body Diameter
24210	17	12	1¾	1¾	1¾	3
24200	25	20	2	2	2	3½
24202	27	22	2	2	2	3½
24204	31	26	2	2	2	3½
24069	23	18	2¼	2¼	2	3½
24201	25	20	2¼	2¼	2	3½
24203	27	22	2¼	2¼	2	3½
24205	31	26	2¼	2½	2	3½
24211	35	30	2¼	2¼	2½	4
24214	28	23	2½	2½	2½	4
24213	45	40	2½	2½	2½	4

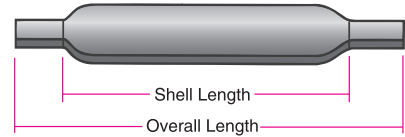

Dual Outlet (Great for pick-up trucks and custom applications!)

Part No.	Overall Length	Shell Length	Inlet I.D.	Outlet O.D.	Body Diameter
24218	33½	23	2½	2¼ (2)	4
24224	29	18	3	2½ (2)	4

(Fully reversible)



THRUSH® GLASSPACK MUFFLERS

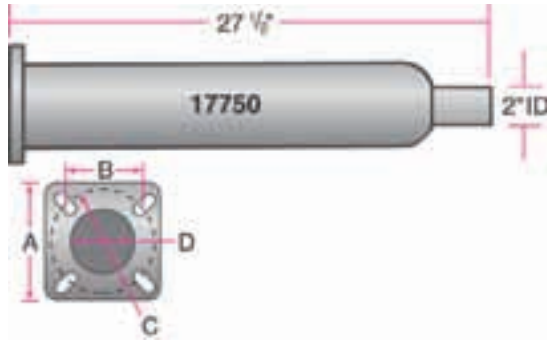

Header Glasspack Muffler

Part No.	A	B	C	D	Body Diameter	Use Gasket No.
17750	4 ³ / ₈	2 ³ / ₄	3 ¹⁵ / ₁₆	2 ⁷ / ₈	3 ¹ / ₂	31347
24221	4 ¹ / ₄	3 ¹³ / ₃₂	3 ¹⁵ / ₁₆	3	4	88201

Fits with 2¹/₂" header collector
Fits with 3" header collector

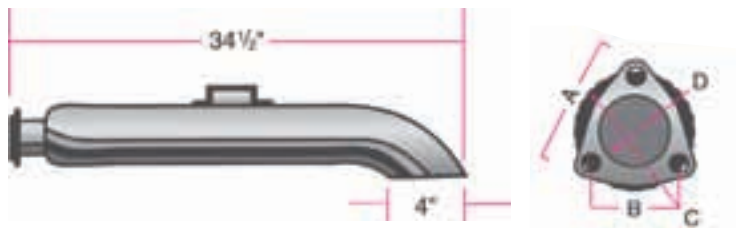

Header Glasspack with Turn Down

- Hanger bolts right up to your vehicle.
- 3 Bolt loose inlet flange. (Fits with 3" header collector)

Part No.	A	B	C	D	Body Diameter	Use Gasket No.
24223	4 ¹ / ₄	3 ¹³ / ₃₂	3 ¹⁵ / ₁₆	3	4	88201

MUFFLERS

PASSENGER CAR SYSTEMS

TRUCK SYSTEMS

DUAL PIPE KITS / HEADERS

THRUSH

ACCESSORIES / UNIV. PIPE

DNX