

# System Diagrams & Kit Contents

## 17340

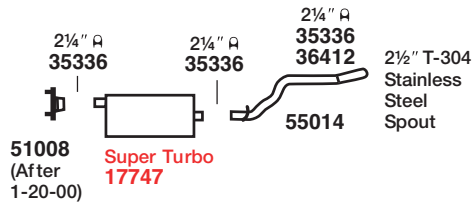

## 17342

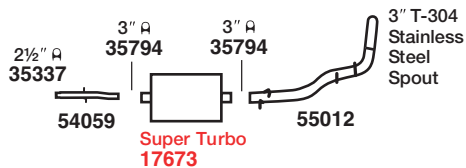

## 17345

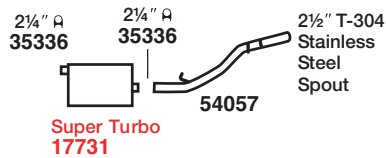

## 17346

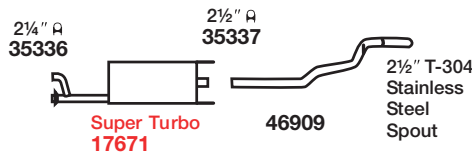

## 17349

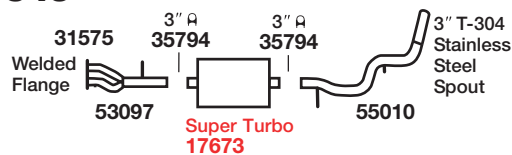

## 17352

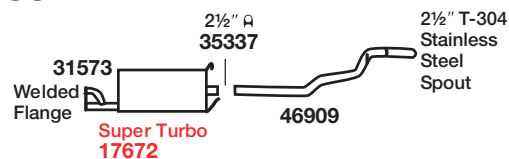

## 17354

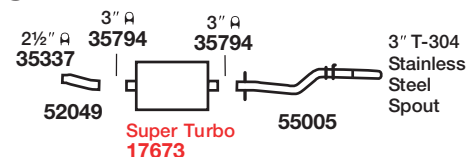

## 17355

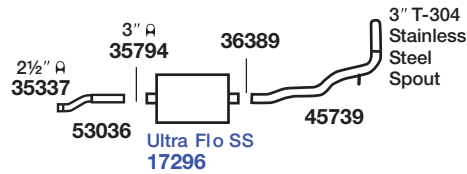

## 17363

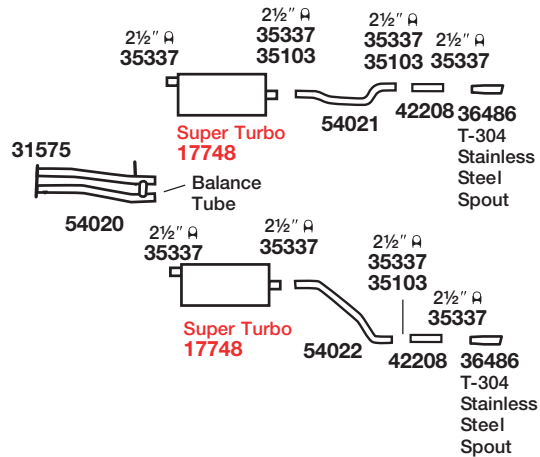

## 17366

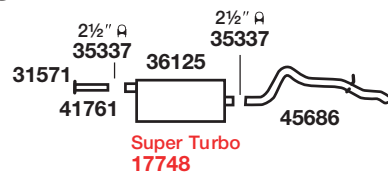

## 17368

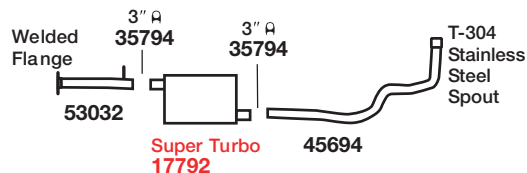

## 17375

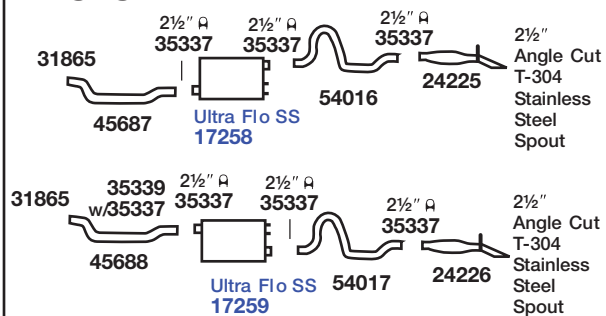

### 17378

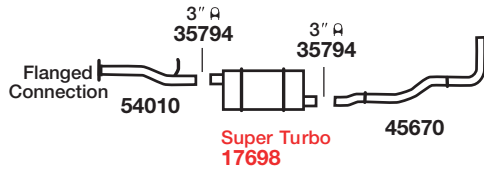

### 17386

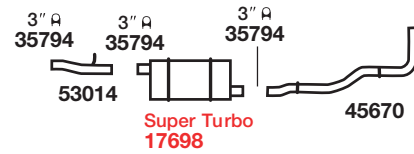

### 17379

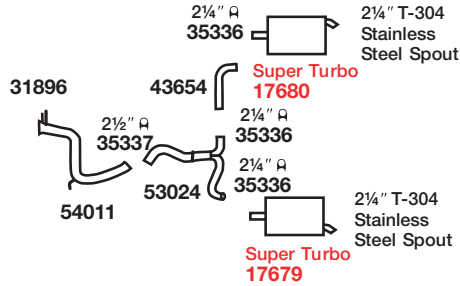

### 17391

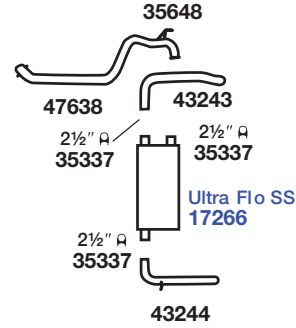

### 17380

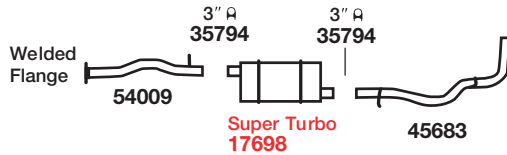

### 17393

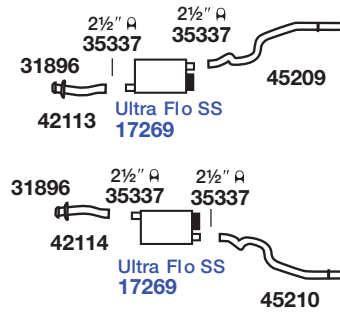

### 17381

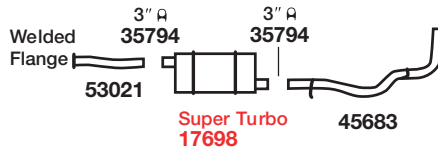

### 17394

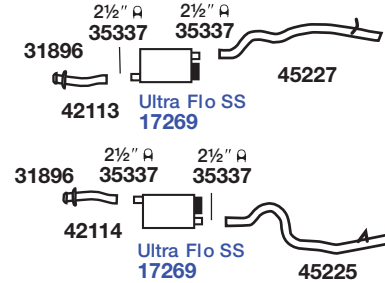

### 17382

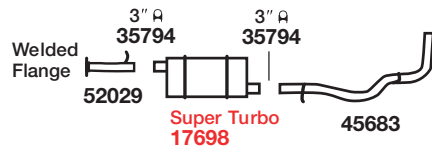

### 17383

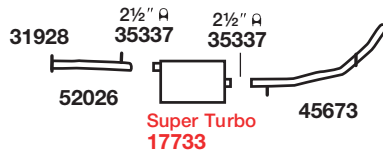

### 17385

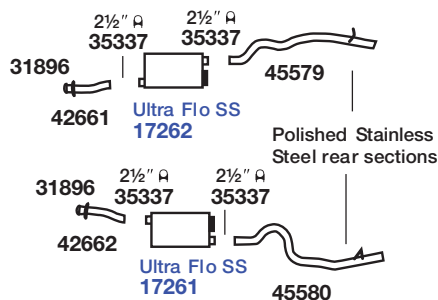

### 17399

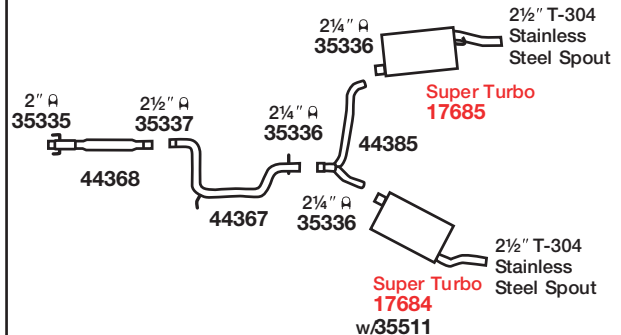

# System Diagrams & Kit Contents

## 17400

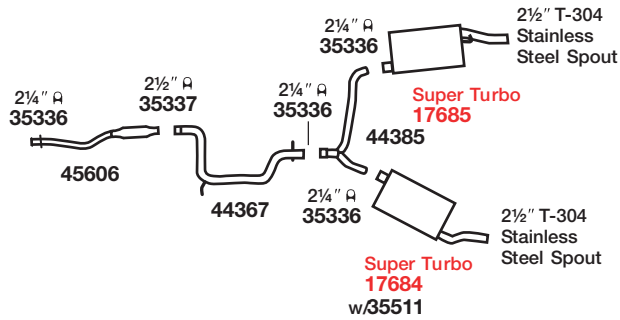

## 17401

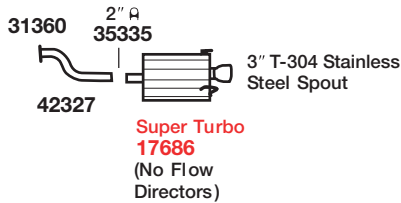

## 17402

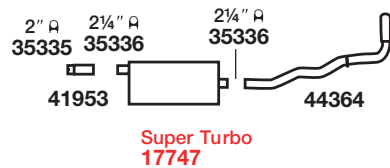

A stock intermediate pipe is required to complete the system installation. Pipe is not included in this kit.

## 17403

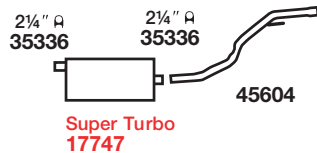

## 17410

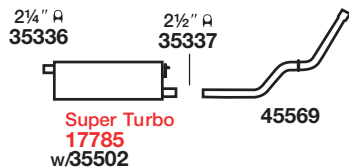

## 17415

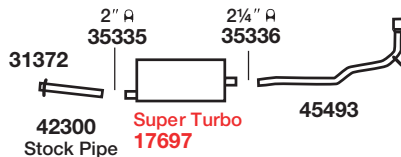

## 17418

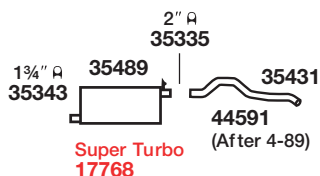

## 17443

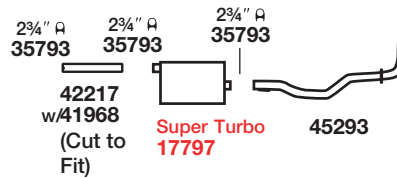

## 17446

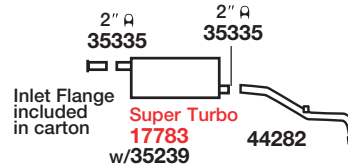

## 17447

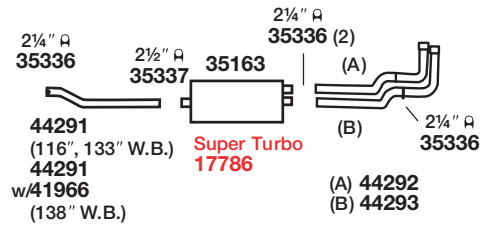

## 17450

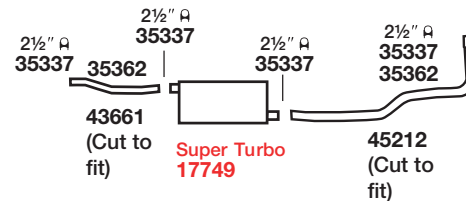

## 17457

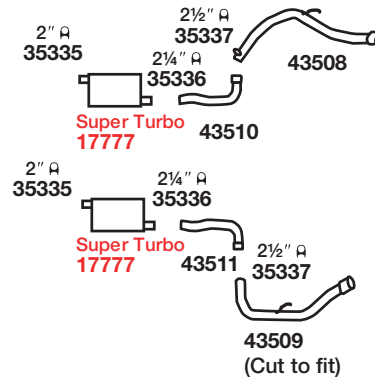

## 17463

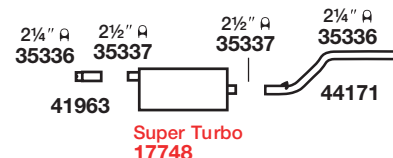

### 17464

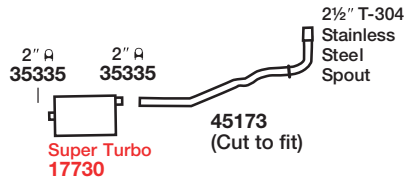

A stock intermediate pipe is required to complete the system installation. Pipe is not included in this kit.

### 17471

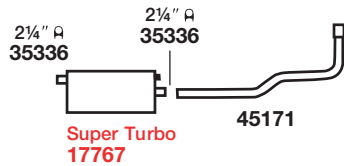

### 17472

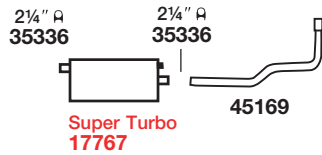

### 17482

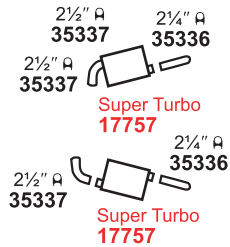

### 17483

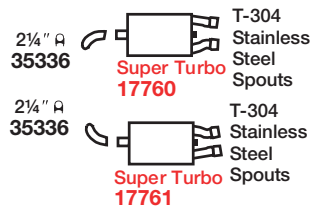

### 17484

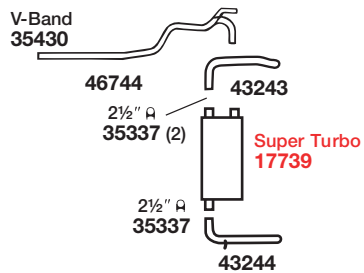

### 17488

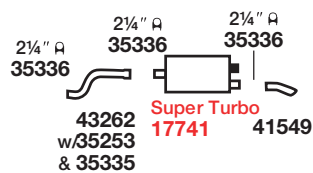

### 17490

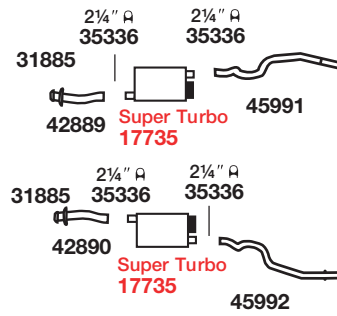

### 17491

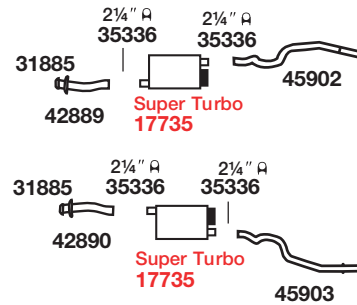

### 17493

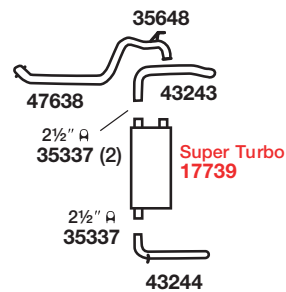

### 17494

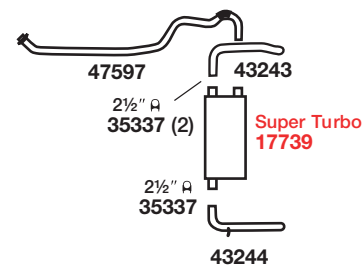

### 17495

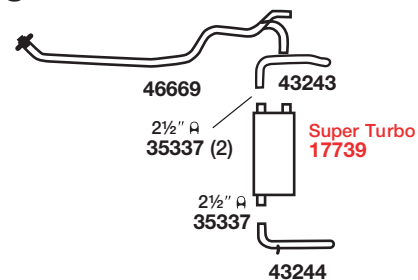

# System Diagrams & Kit Contents

## 19301

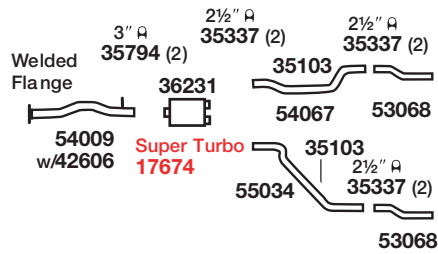

## 19305

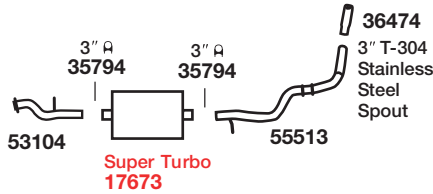

## 19308

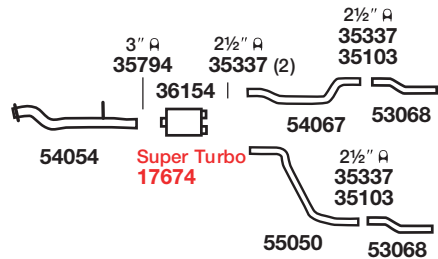

## 19309

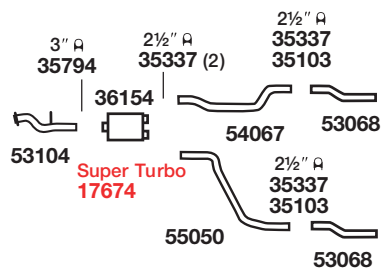

## 19311

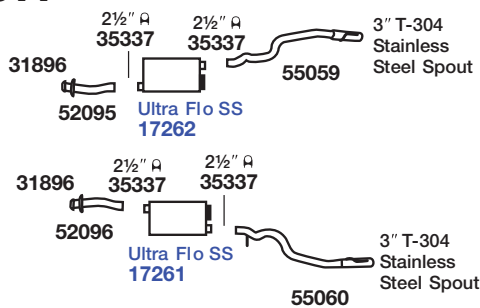

## 19312

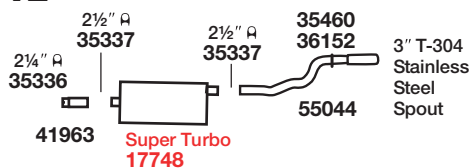

## 19319

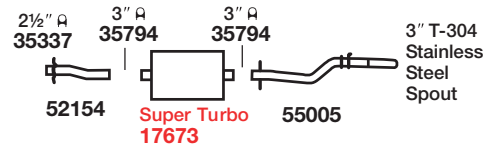

## 19321

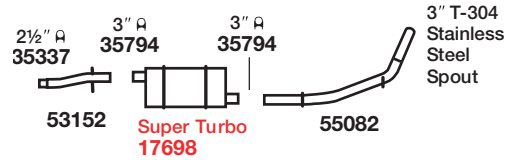

## 19327

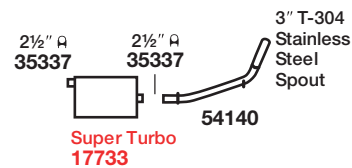

## 19328

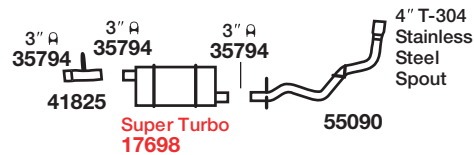

## 19330

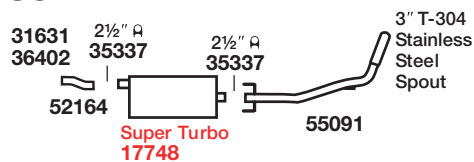

## 19331

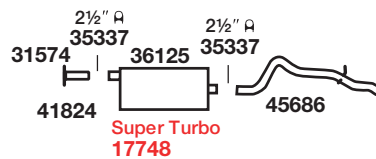

## 19332

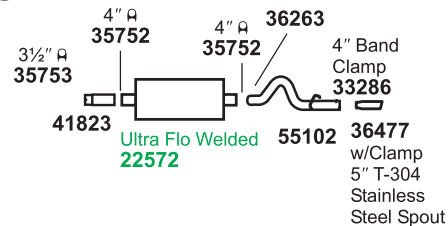

### 19360

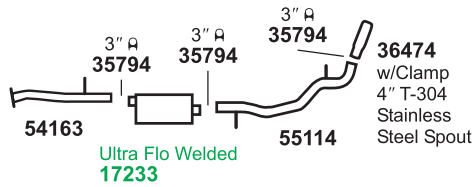

### 19373

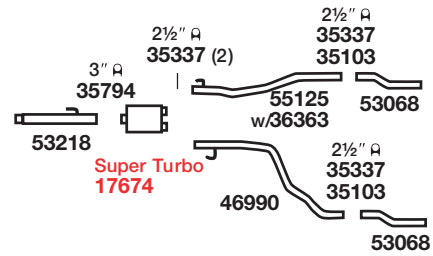

### 19361

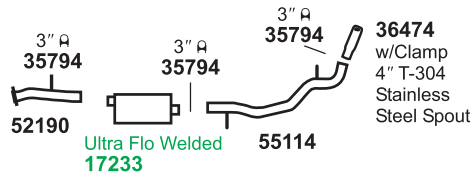

### 19374

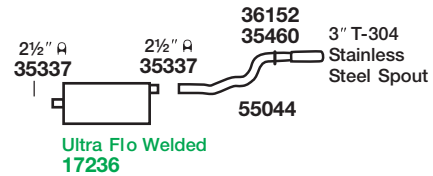

### 19362

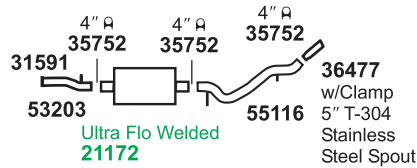

### 19383

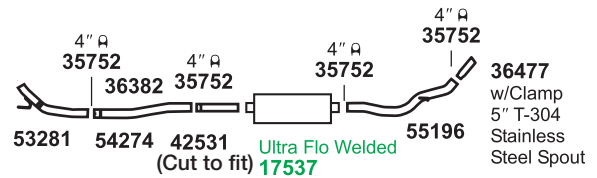

### 19363

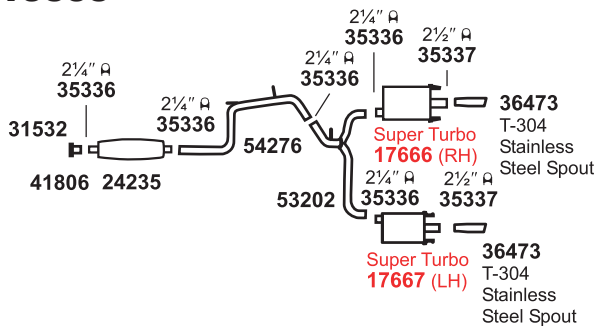

### 19386

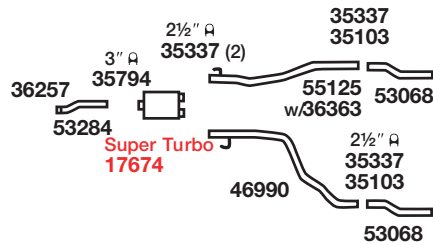

### 19369

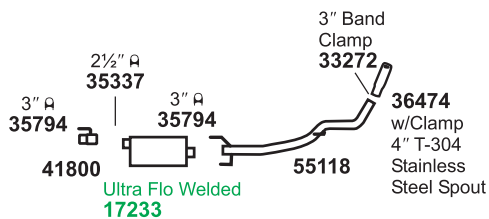

### 19387

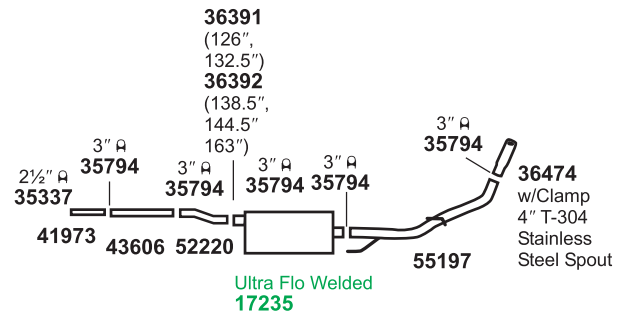

### 19370

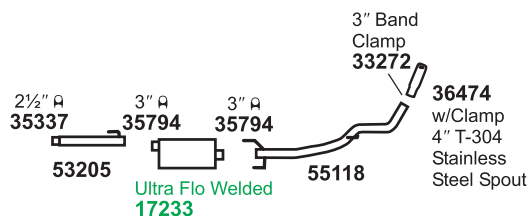

### 19388

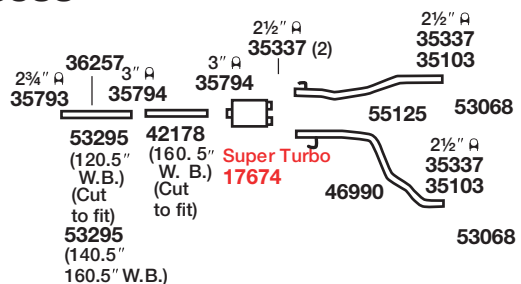

# System Diagrams & Kit Contents

## 19389

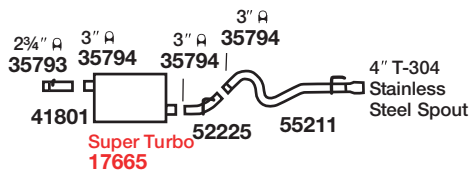

## 19391

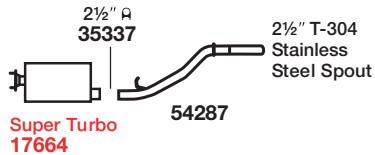

## 19392

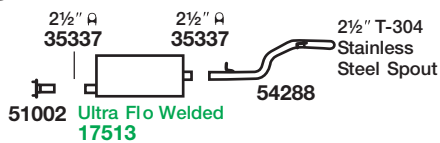

## 19396

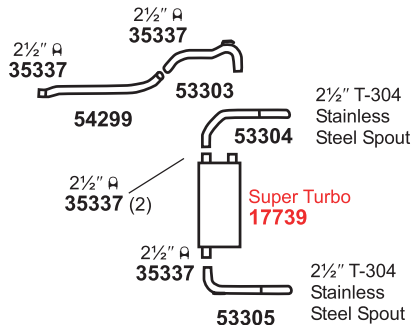

## 19397

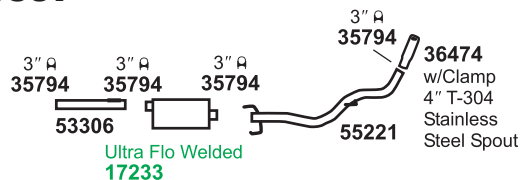

## 19399

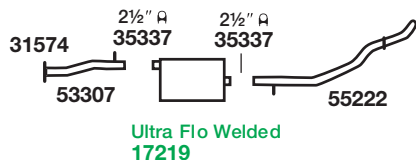

## 19403

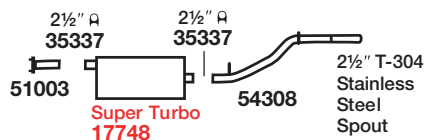

## 19410

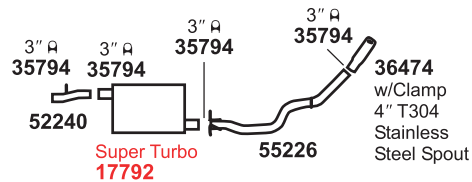

## 19411

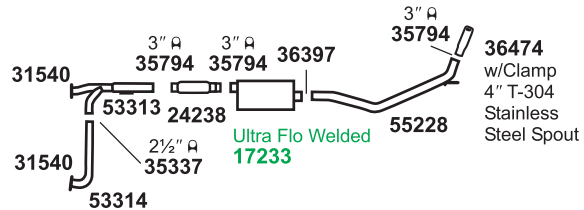

## 19412

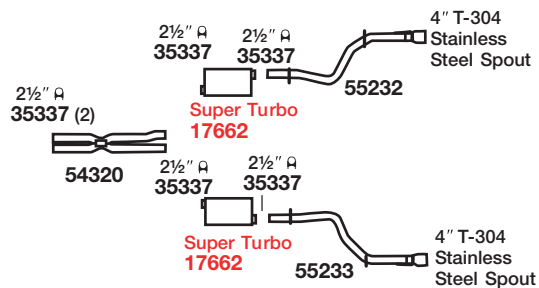

## 19413

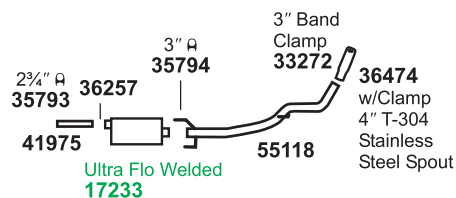

### 19418

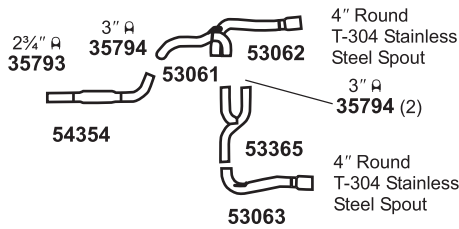

### 19426

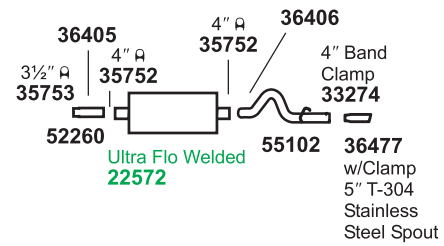

### 19419

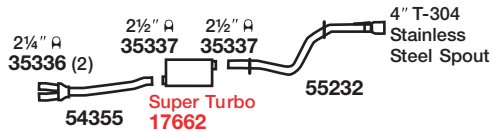

### 19427

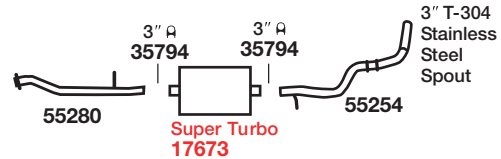

### 19420

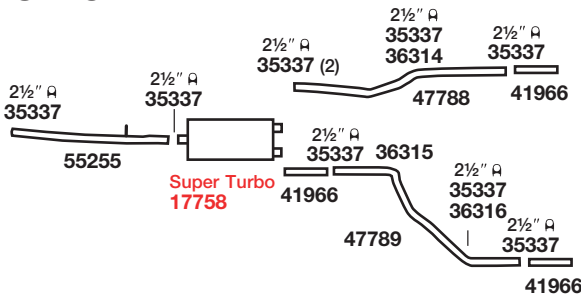

### 19428

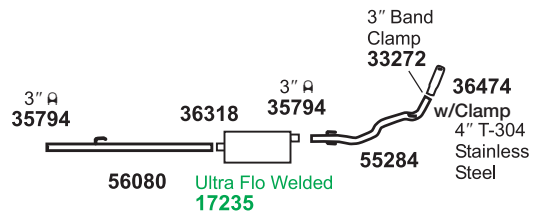

### 19421

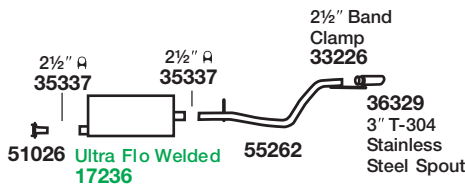

### 19430

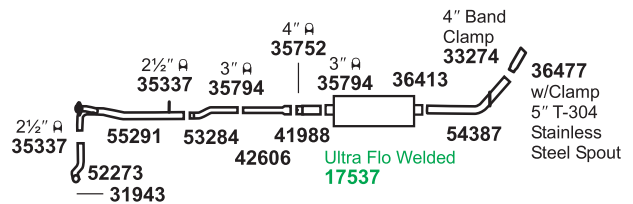

### 19422

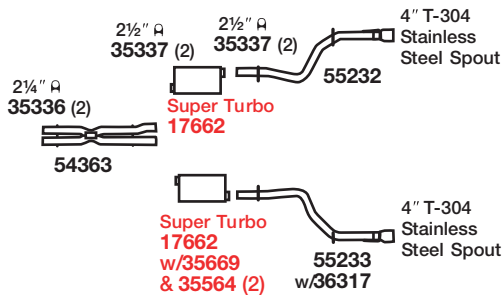

### 19431

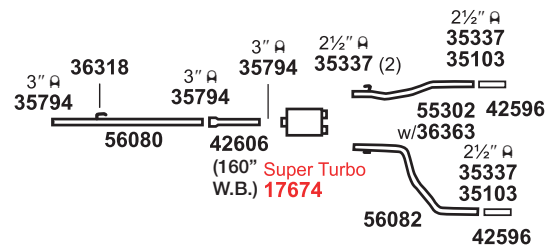

### 19424

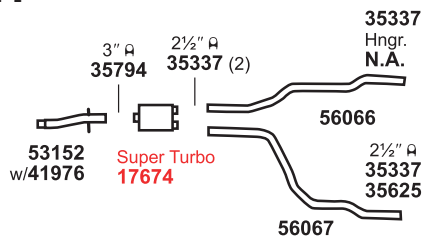

# System Diagrams & Kit Contents

## 19432

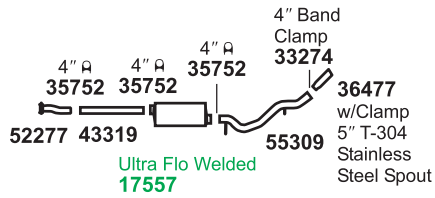

## 19441

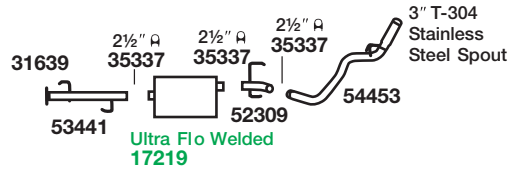

## 19436

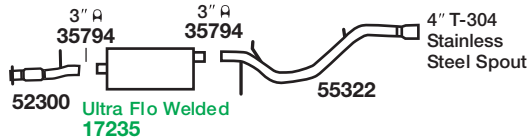

## 19442

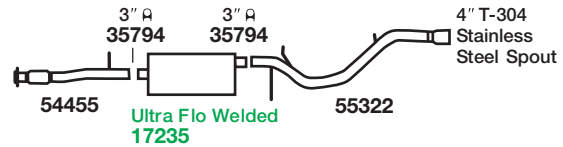

## 19437

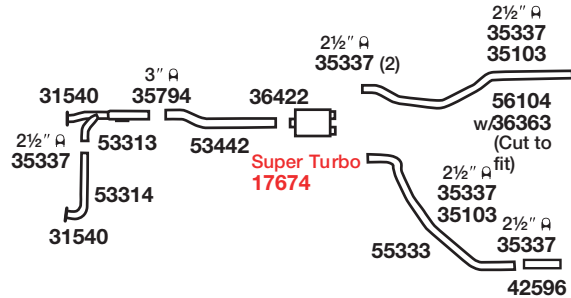

## 19443

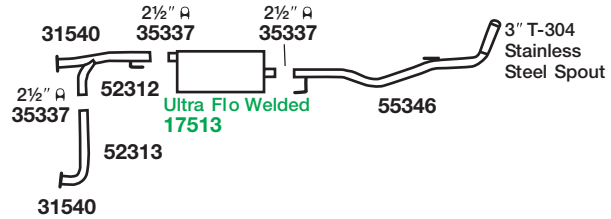

## 19438

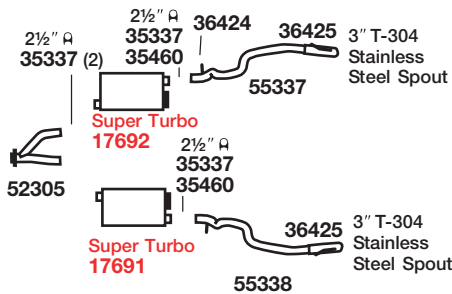

## 19444

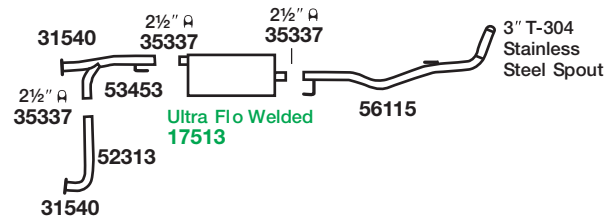

## 19440

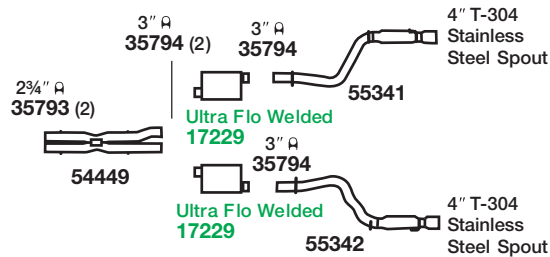

## 19446

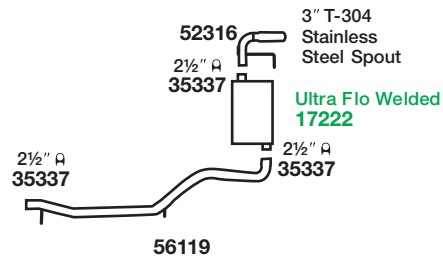

### 19449

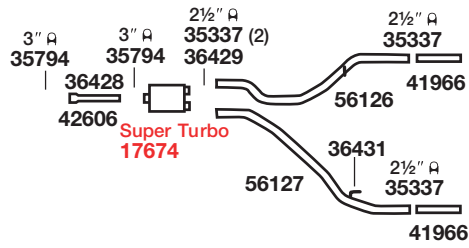

### 19451

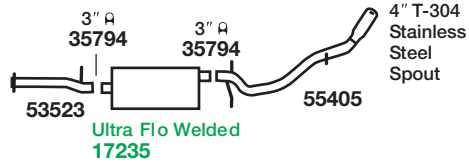

### 19452

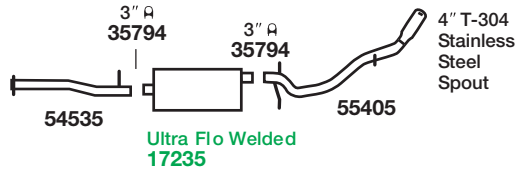

### 19455

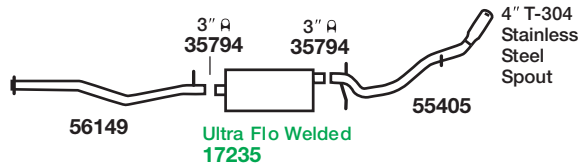

### 19456

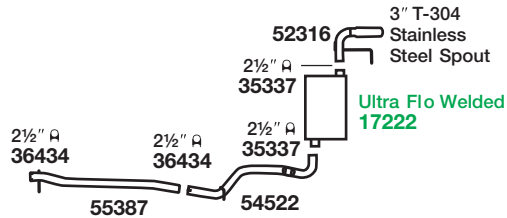

### 19458

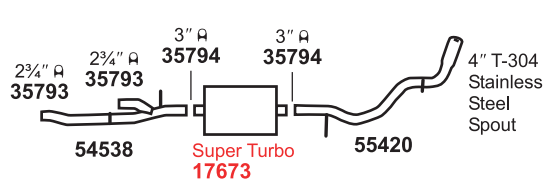

### 19461

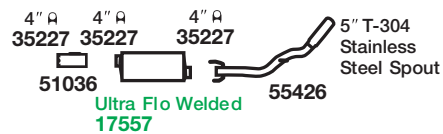

### 19465

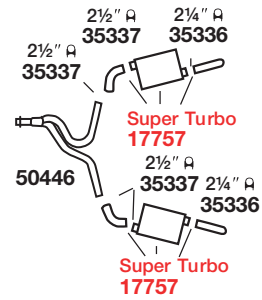

### 19467

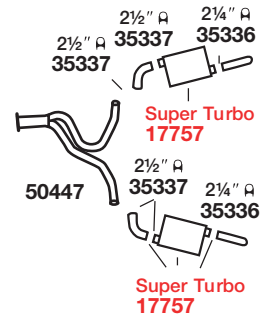

### 19469

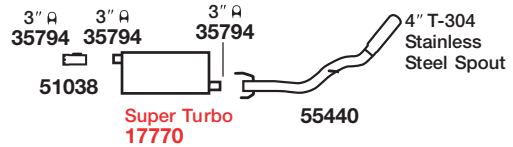

### 19470

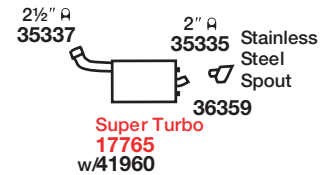
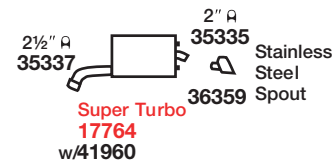

# System Diagrams & Kit Contents

## 19472

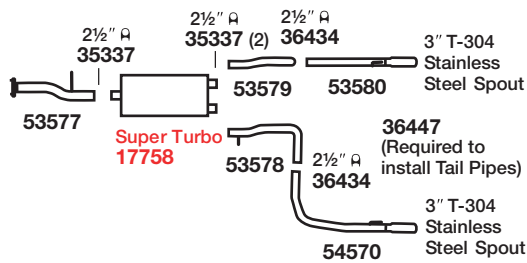

NOTE: Spare tire must be removed when installing this dual tail pipe kit.

## 19481

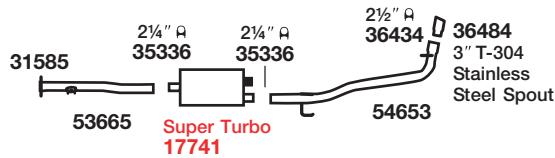

## 19482

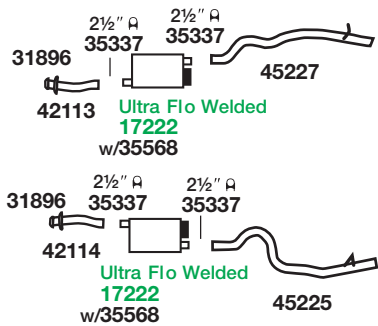

## 19483

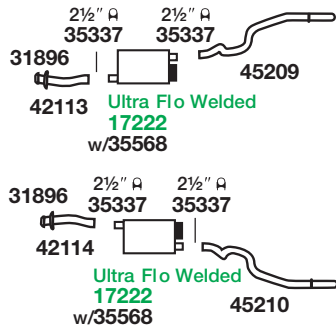

## 19485

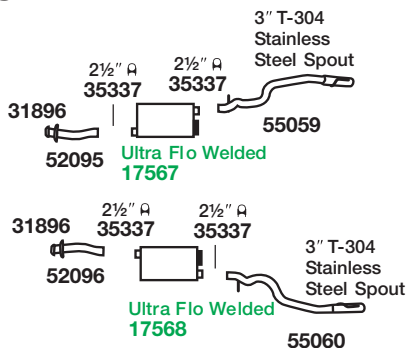

## 38023 SS

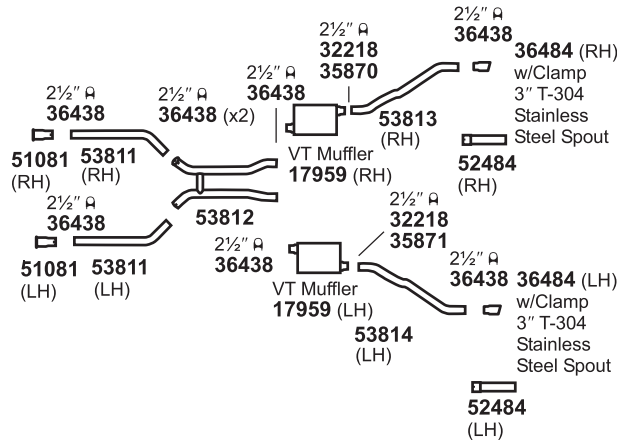

## 38025 SS

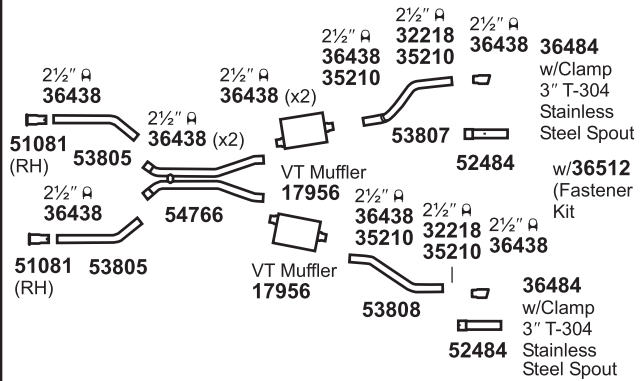

## 38026 SS

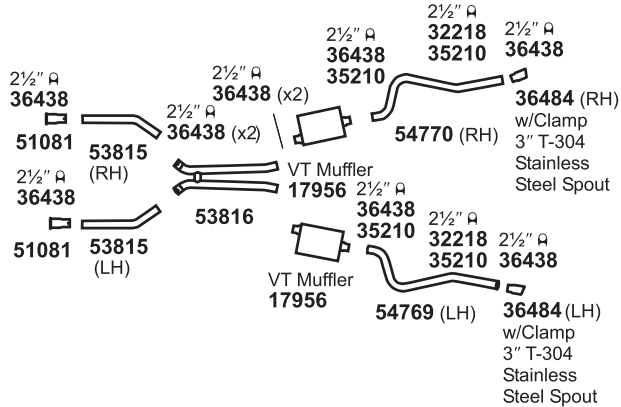

## 38311 SS

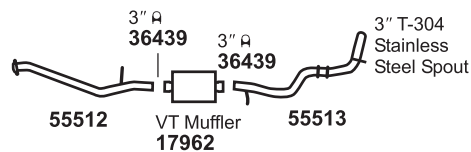

**38397 SS**

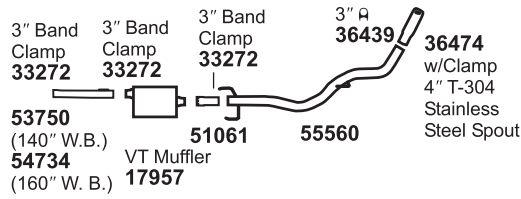

**38456 SS**

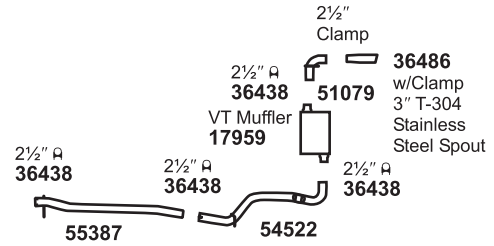

**38446 SS**

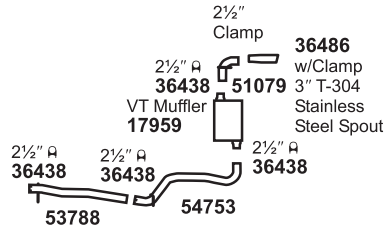

**38486 SS**

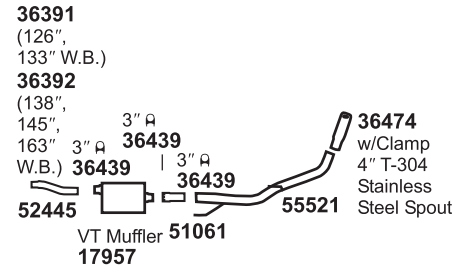

**38450 SS**

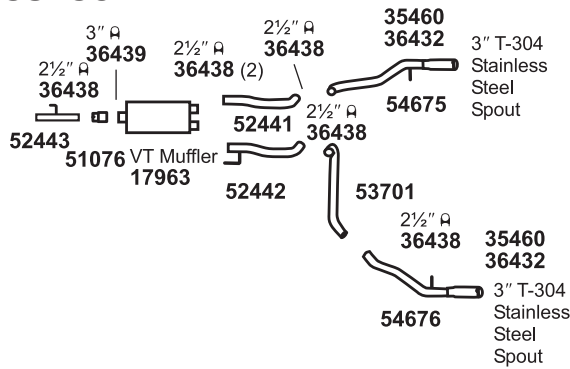

**38488 SS**

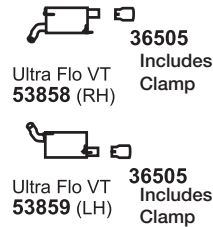

**38453 SS**

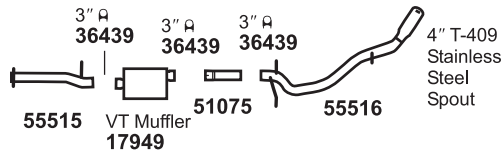

**38493 SS**

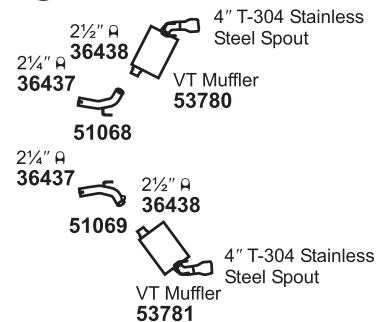

**38454 SS**

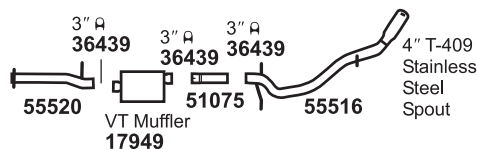

**38494 SS**

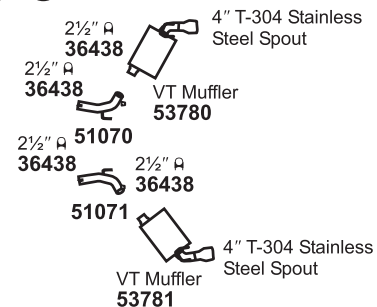

# System Diagrams & Kit Contents

## 38495 SS

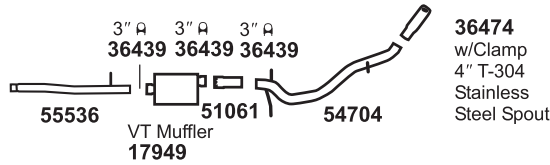

## 38497 SS

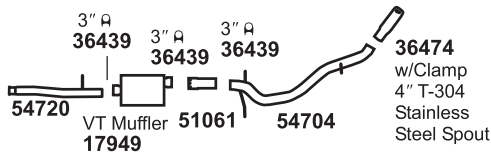

## 38501 SS

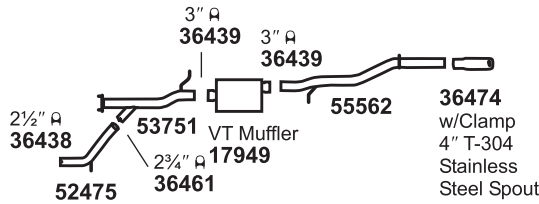

## 38503 SS

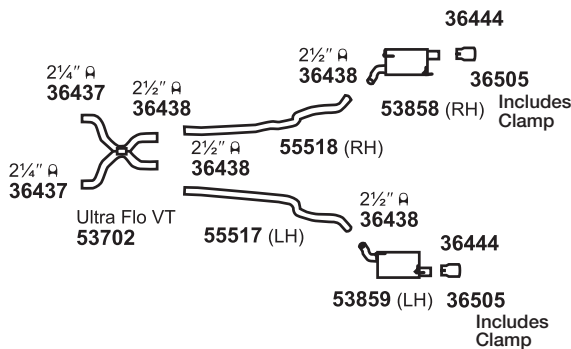

## 38504 SS

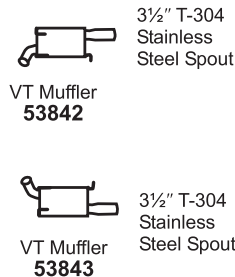

## 38507 SS

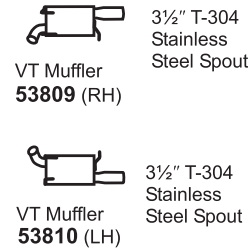

## 38508 SS

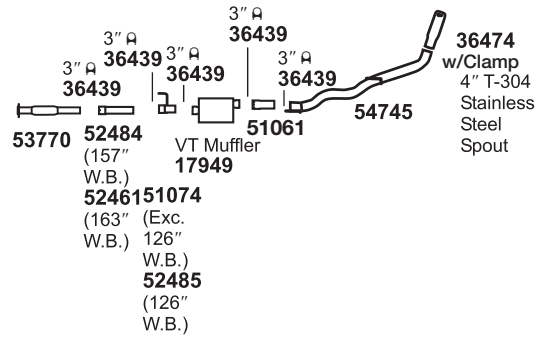

## 38512 SS

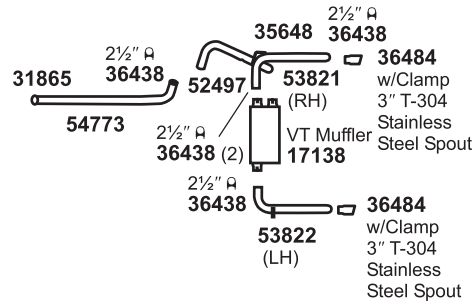

## 38514 SS

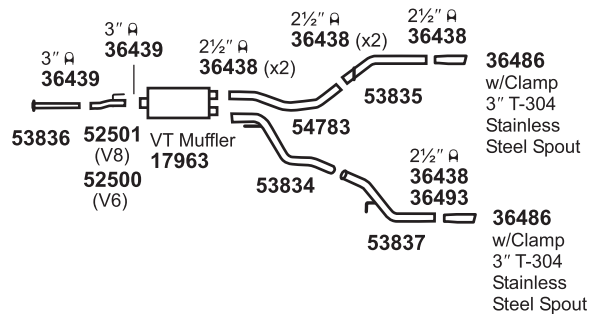

## 38515 SS

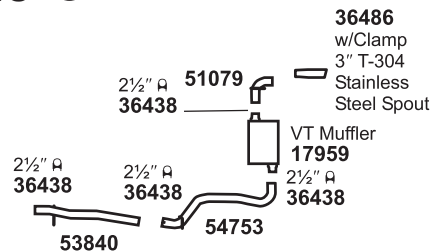

**38517 SS**

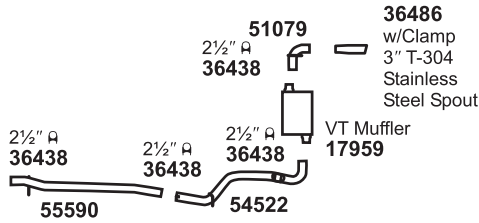

**38520 SS**

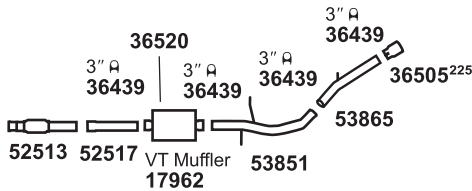

**38526 SS**

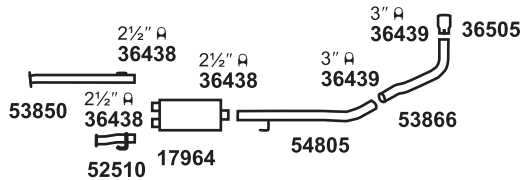

**38527 SS**

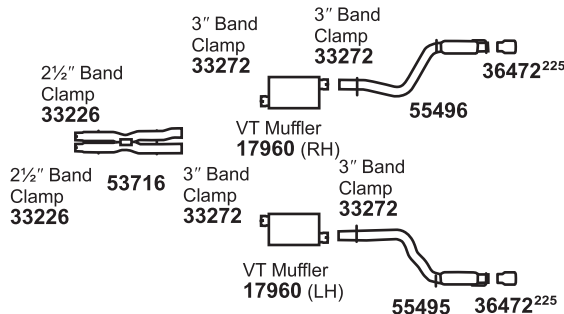

**38528 SS**

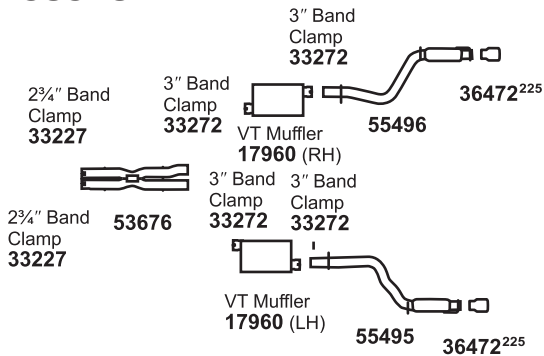

**39310 SS**

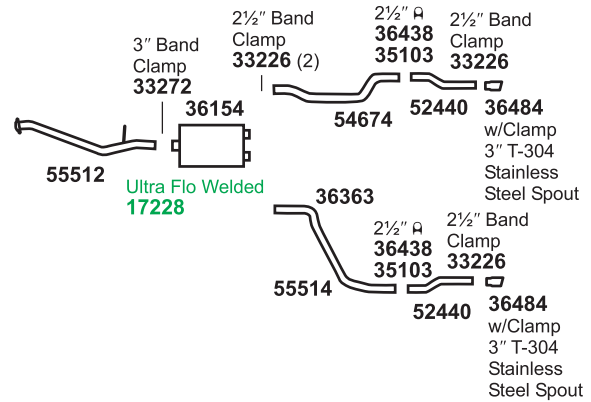

**39311 SS**

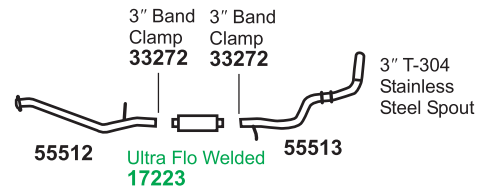

**39315 SS**

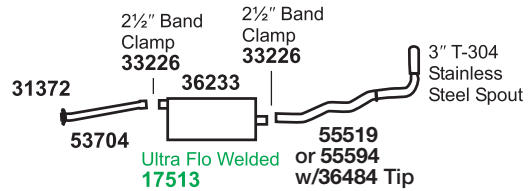

**39321 SS**

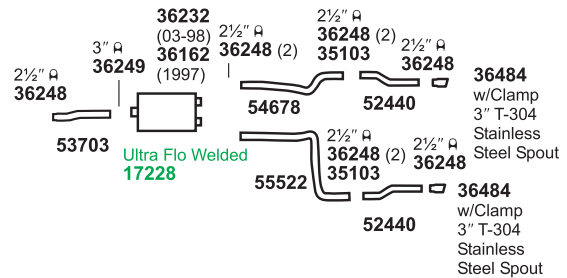

**39375 SS**

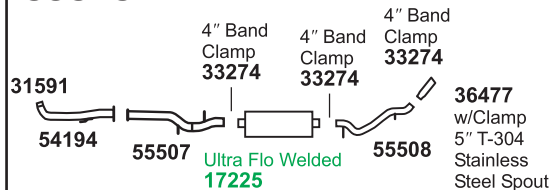

# System Diagrams & Kit Contents

## 39376 SS

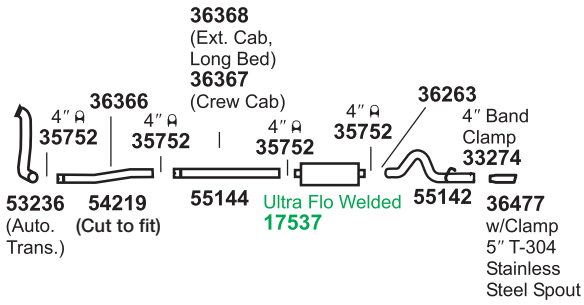

## 39377 SS

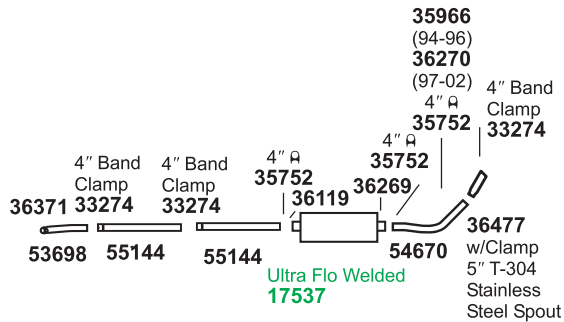

## 39378 SS

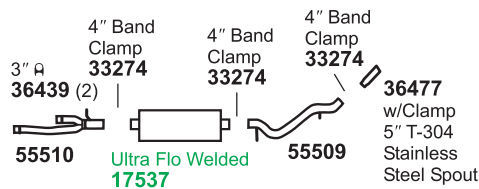

## 39379 SS

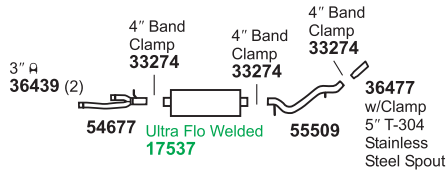

## 39397 SS

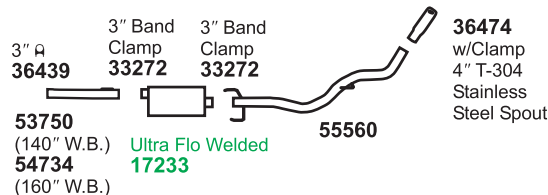

## 39414 SS

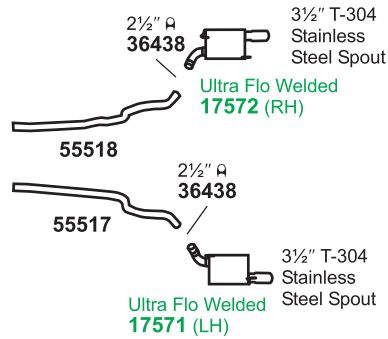

## 39425 SS

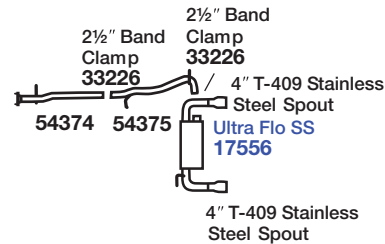

## 39432 SS

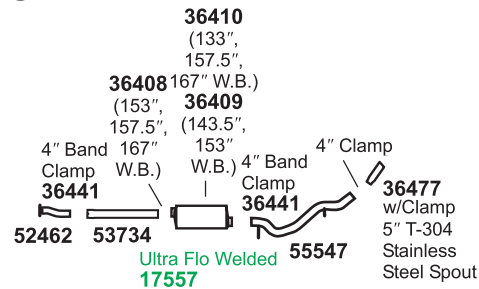

## 39434 SS

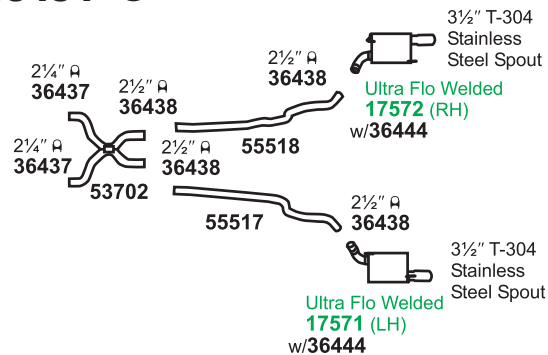

## 39435 SS

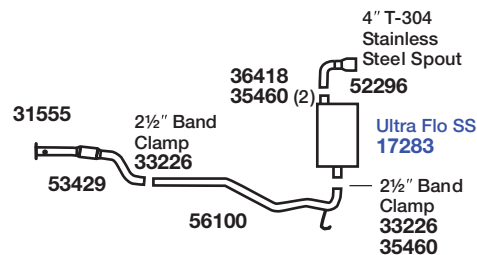

**39445 SS**

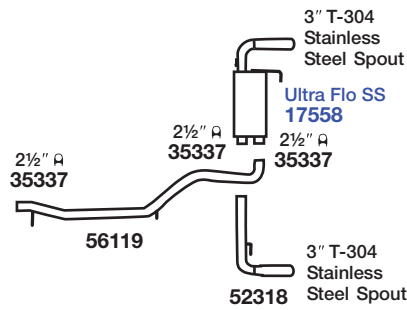

**39446 SS**

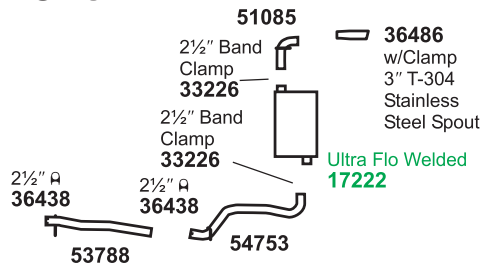

**39447 SS**

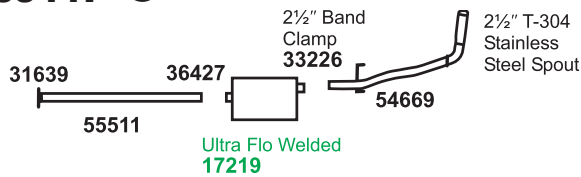

**39448 SS**

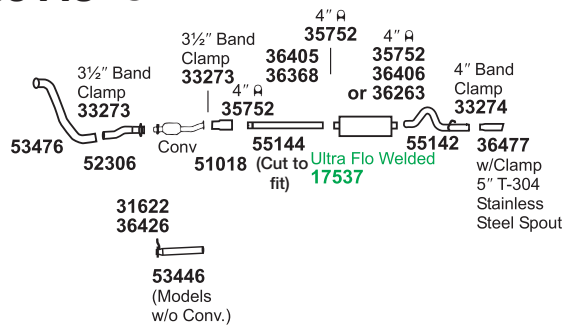

**39450 SS**

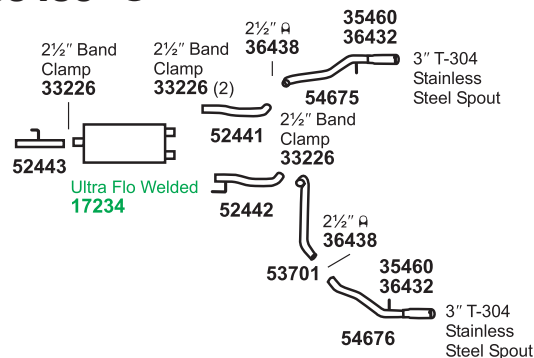

**39453 SS**

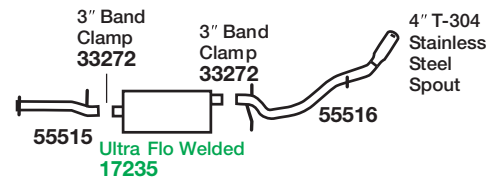

**39454 SS**

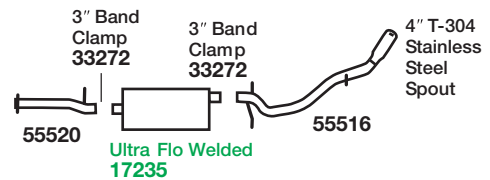

**39456 SS**

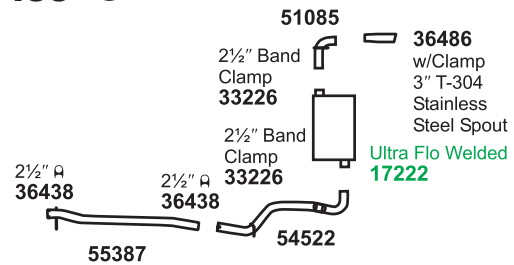

**39457 SS**

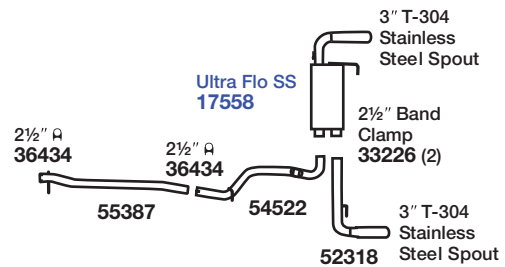

**39459 SS**

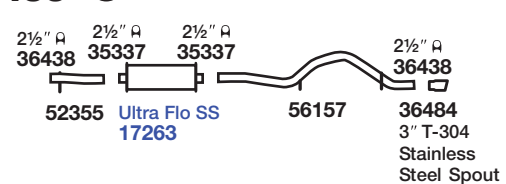

**39460 SS**

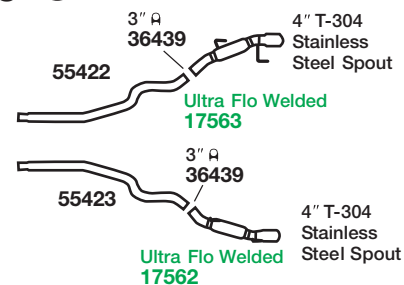

# System Diagrams & Kit Contents

## 39461 SS

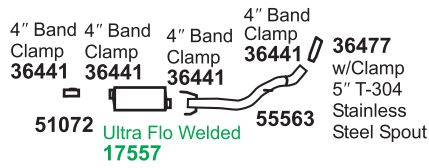

## 39462 SS

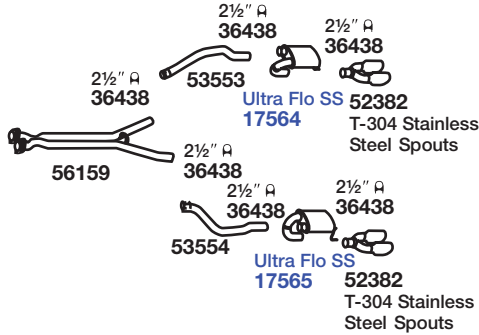

## 39464 SS

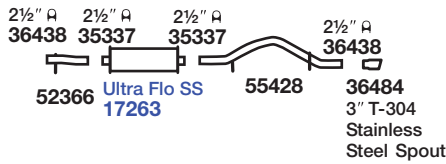

## 39468 SS

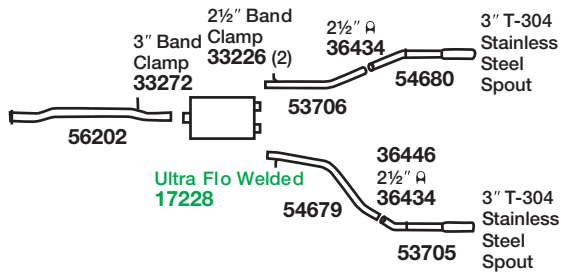

## 39469 SS

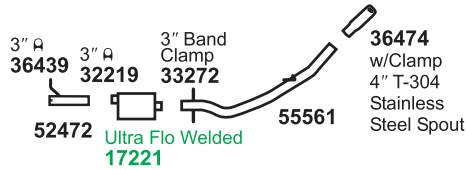

## 39471 SS

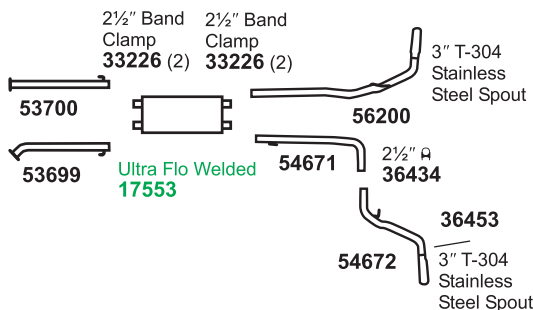

## 39475 SS

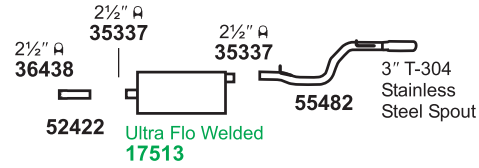

## 39477 SS

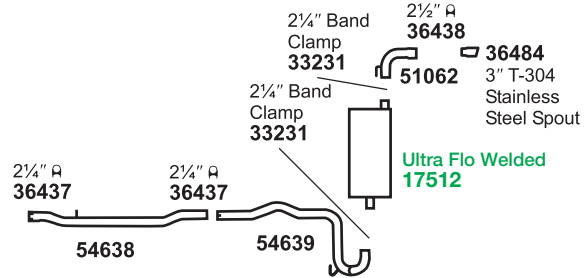

## 39478 SS

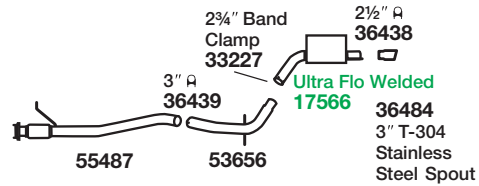

## 39480 SS

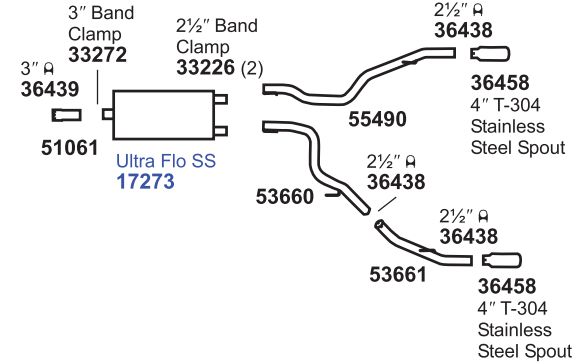

## 39484 SS

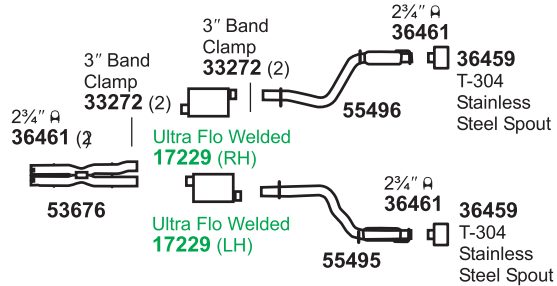

## 39486 SS

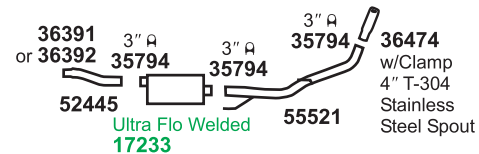

**39487 SS**

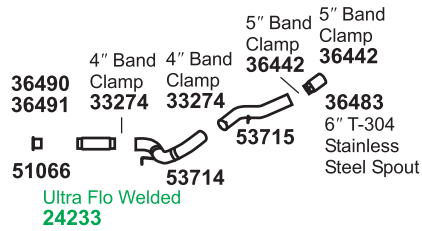

**39488 SS**

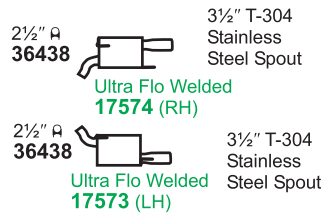

**39489 SS**

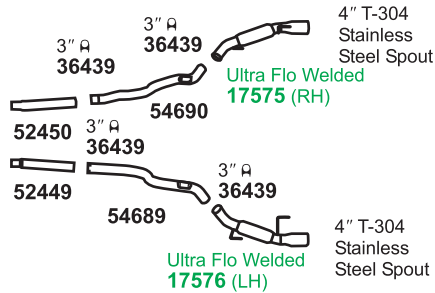

**39490 SS**

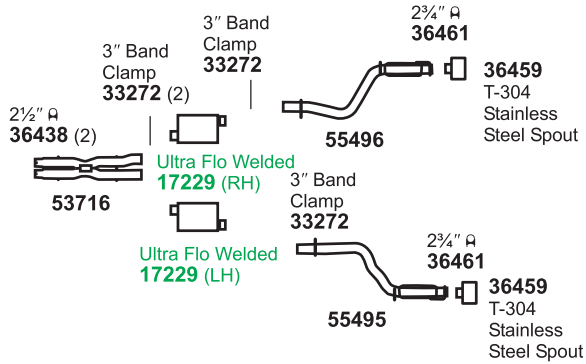

**39491 SS**

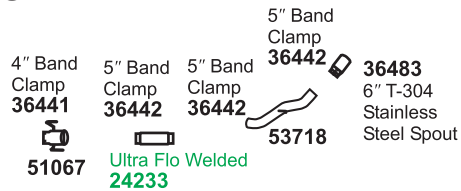

**39492 SS**

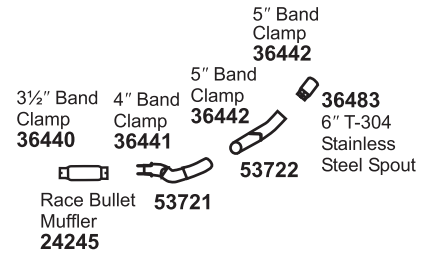

**39493 SS**

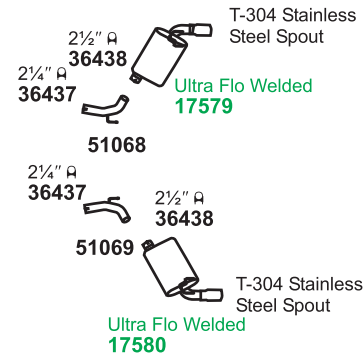

**39494 SS**

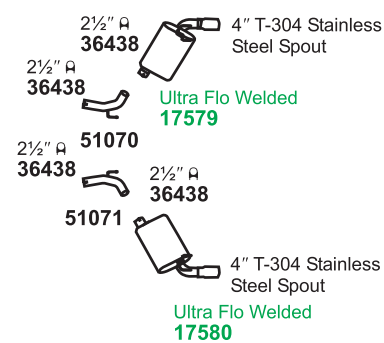

**39495 SS**

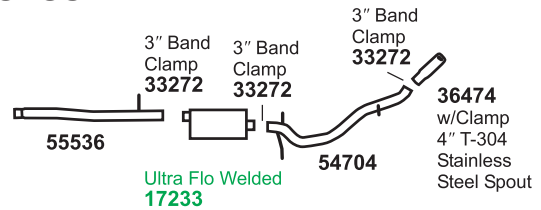

**39496 SS**

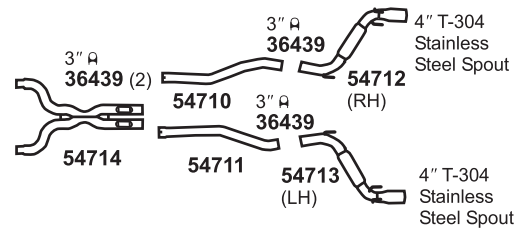

# System Diagrams & Kit Contents

## 39497 SS

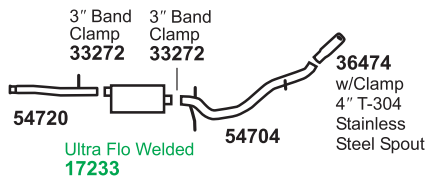

## 39498 SS

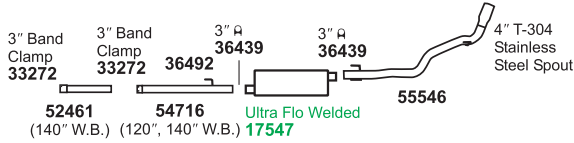

## 39499 SS

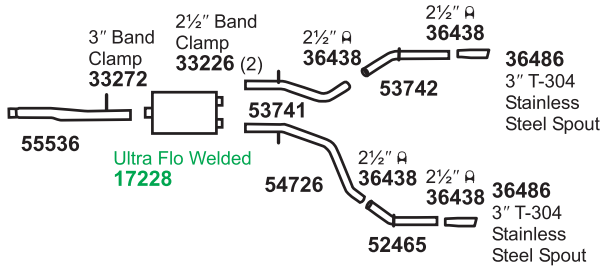

## 39500 SS

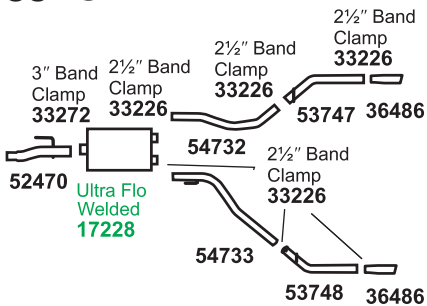

## 39501 SS

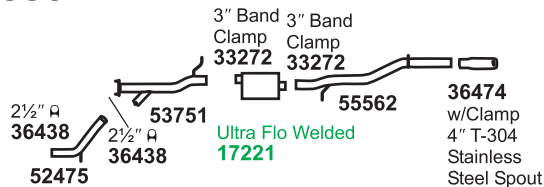

## 39502 SS

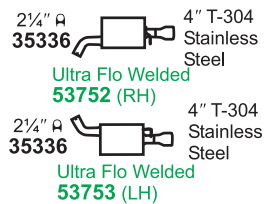

## 39503 SS

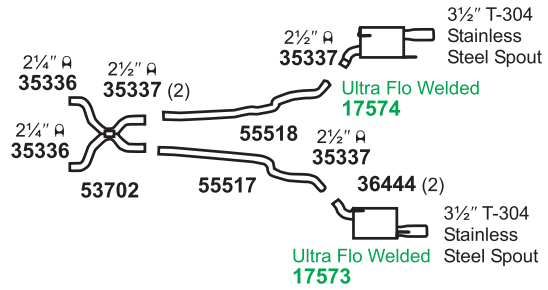

## 39504 SS

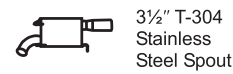

### Reuse Inlet Clamp

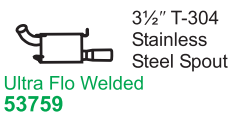

## 39505 SS

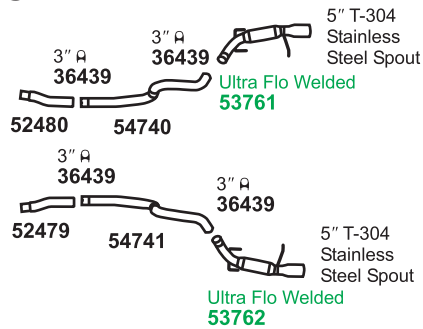

## 39506 SS

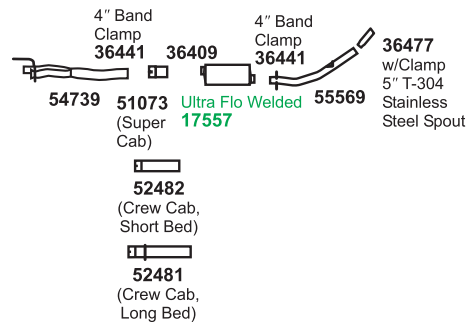



# System Diagrams & Kit Contents

## 39518 SS

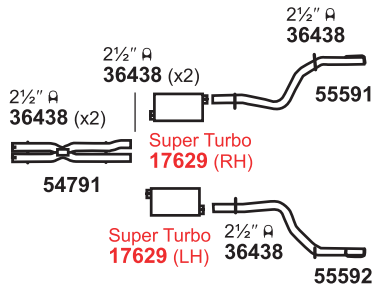

## 39519 SS

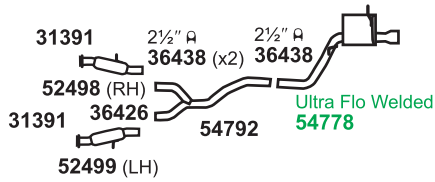

## 39521 SS

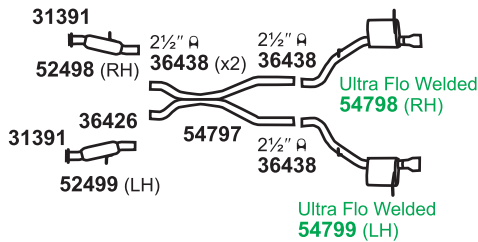

## 39522 SS

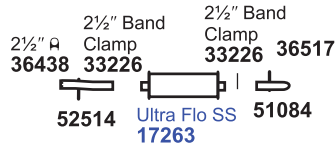

## 39523 SS

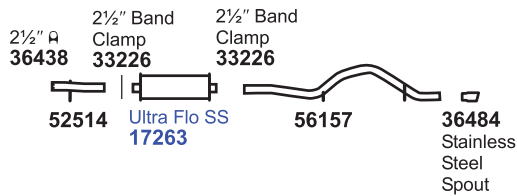

## 39524 SS

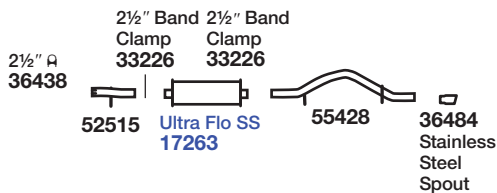

## 39525 SS

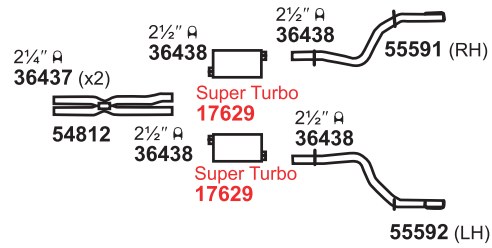

**NOTE: DynoMax system fits only models w/factory dual exhaust. O.E. tips are attached to the vehicle rear fascia and are reused w/DynoMax system.**

## 88344

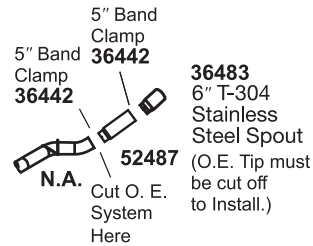

## 88345

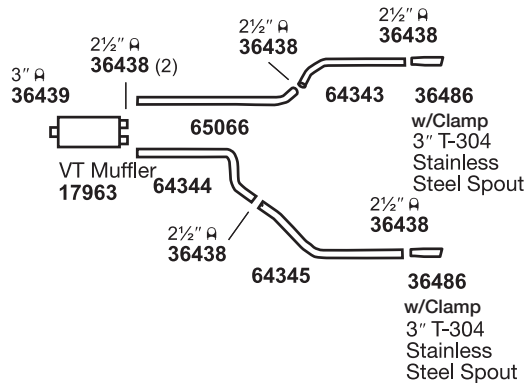

**NOTE: Pipe Modifications Required for Installations.**

## 88346

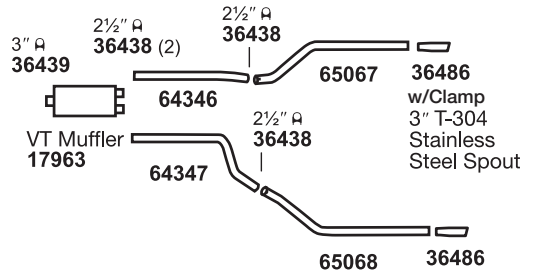

**NOTE: Pipe Modifications Required for Installations.**