



STAINLESS STEEL AXLE-BACK DRONE-FREE PERFORMANCE EXHAUST

2013-10 CHEVY CAMARO SS 6.2L V8¹

- Stainless Steel DynoMax VT[®] Muffler Assemblies
- 4-in. outlet, double wall, buffed and polished, 6-in. OAL SS slant cut tips
- 2.5-in. SS mandrel pipes

PART NUMBER 38494

14 HORSEPOWER
15 LB-FT. TORQUE
IMPROVEMENT



2013-10 CHEVY CAMARO 3.6L V6¹

- Stainless Steel DynoMax VT[®] Muffler Assemblies
- 4-in. outlet, double wall, buffed and polished, 6-in. OAL SS slant cut tips
- 2.5-in. SS mandrel pipes

PART NUMBER 38493

16 HORSEPOWER
21 LB-FT. TORQUE
IMPROVEMENT



DRONE-FREE PERFORMANCE.™
MUFFLER

LIMITED LIFETIME WARRANTY +
90-DAY PERFORMANCE AND SOUND GUARANTEE*
on all systems

STAINLESS STEEL PERFORMANCE EXHAUST

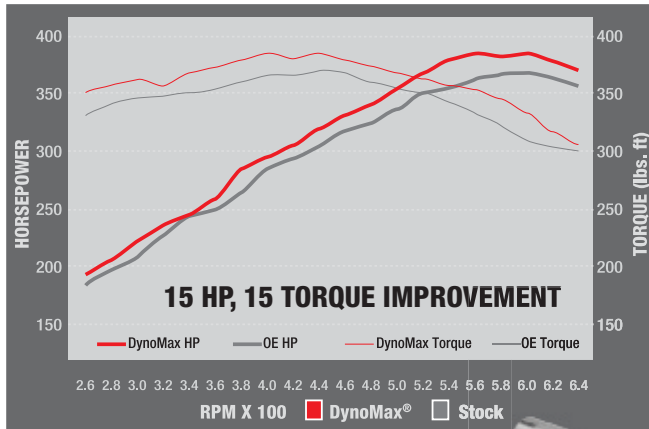

2013-10 CHEVY CAMARO SS 6.2L V8¹

- Stainless Steel Race Bullet Welded Muffler Assemblies
- 4-in. outlet, double wall, buffed and polished, 6-in. OAL SS slant cut tips
- 3-in. SS mandrel pipes

PART NUMBER 39496

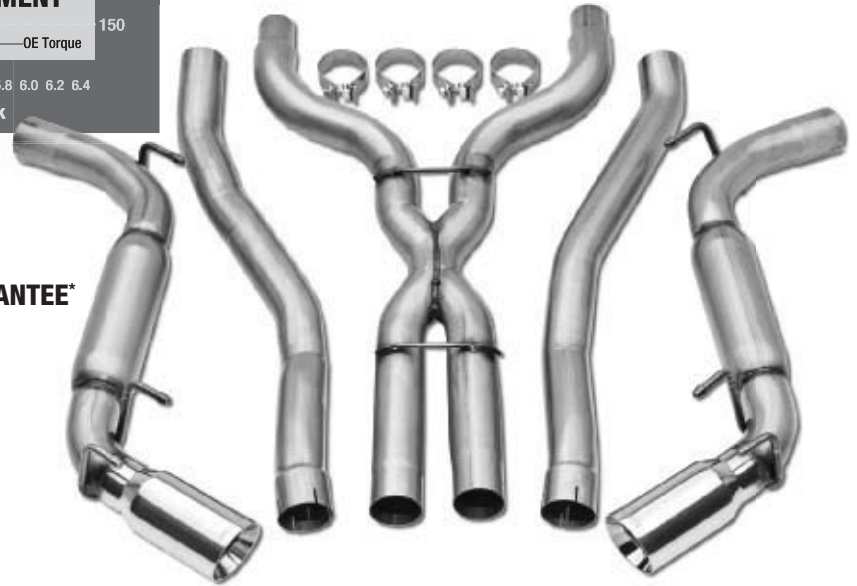

**LIMITED LIFETIME WARRANTY +
90-DAY PERFORMANCE AND SOUND GUARANTEE***
on all systems

2013-10 CHEVY CAMARO SS 6.2L V8¹

- Stainless Steel Ultra Flo™ Welded Muffler Assemblies
- 4-in. outlet, double wall, buffed and polished, 6-in. OAL SS slant cut tips
- 2.5-in. SS mandrel pipes

PART NUMBER 39494 (not shown)

**14 HORSEPOWER
15 LB.-FT. TORQUE
IMPROVEMENT**

AXLE-BACK SYSTEMS

2013-10 CHEVY CAMARO 3.6L V6¹

- Stainless Steel Ultra Flo™ Welded Muffler Assemblies
- 4-in. outlet, double wall, buffed and polished, 6-in. OAL SS slant cut tips
- 2.5-in. SS mandrel pipes

PART NUMBER 39493 (not shown)

**16 HORSEPOWER
21 LB.-FT. TORQUE
IMPROVEMENT**



¹Except convertible

*For more information visit dynamax.com



STAINLESS STEEL PERFORMANCE EXHAUST

2013-08 DODGE SRT8 CHALLENGER 6.1L, 6.4L HEMI

- Stainless Steel Ultra Flo™ Welded Mufflers
- 4x7-in. outlet, single wall, buffed and polished, 6-in. OAL SS slant cut tips
- 3-in. SS mandrel pipes

PART NUMBER 39484

24 HORSEPOWER
23 LB-FT. TORQUE
IMPROVEMENT

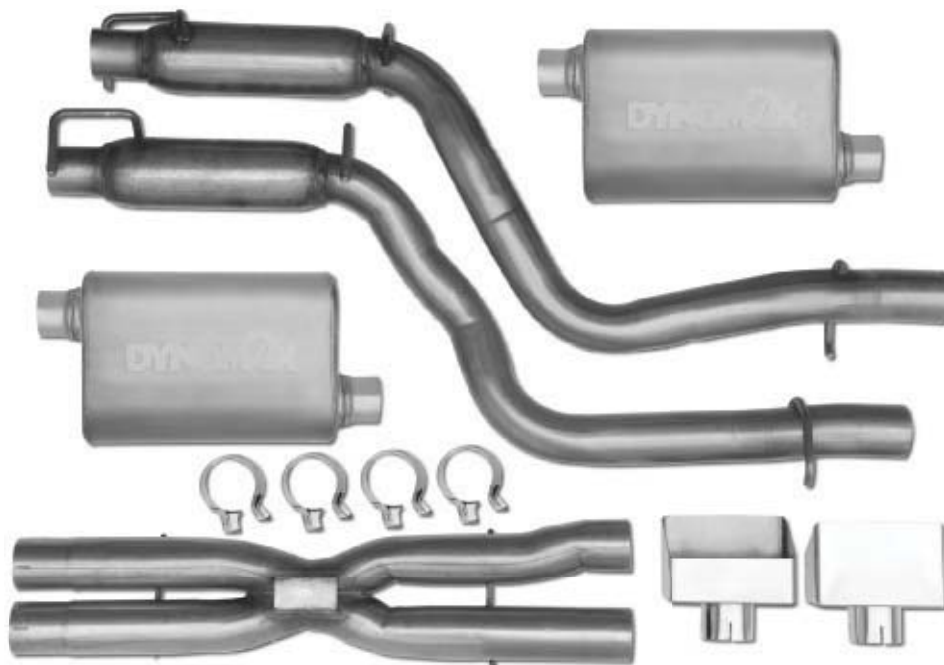

2013-08 DODGE R/T CHALLENGER 5.7L HEMI

- Stainless Steel Ultra Flo™ Welded Mufflers
- 4x7-in. outlet, single wall, buffed and polished, 6-in. OAL SS slant cut tips
- 3-in. SS mandrel pipes

PART NUMBER 39490

11 HORSEPOWER
24 LB-FT. TORQUE
IMPROVEMENT

**LIMITED LIFETIME WARRANTY +
90-DAY PERFORMANCE AND SOUND GUARANTEE***
on all systems



STAINLESS STEEL AXLE-BACK DRONE-FREE PERFORMANCE EXHAUST

2014-11 FORD MUSTANG 3.7L V6

- Stainless Steel DynoMax VT® Muffler Assemblies
- 3.5-in. outlet, double wall, buffed and polished, 10-in. OAL SS slant cut tips
- 2.75-in. SS mandrel pipes
- Original Equipment style rod hangers

PART NUMBER 38507

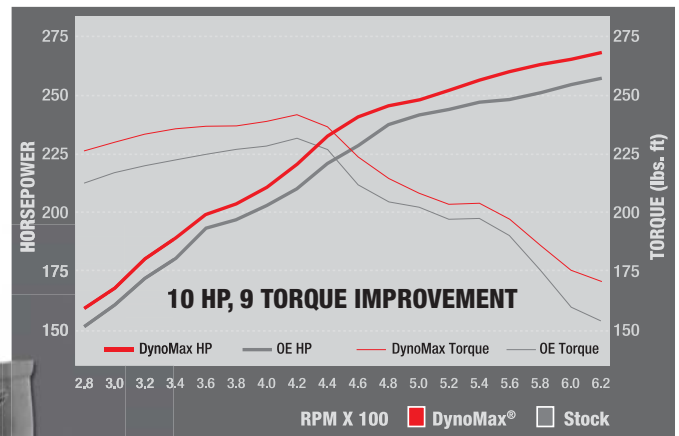

DRONE-FREE PERFORMANCE.™
MUFFLER

2014-12 FORD MUSTANG BOSS 302 5.0L V8

2014-11 FORD MUSTANG GT 5.0L V8

2013-11 FORD MUSTANG SHELBY GT500 5.4L, 5.8L V8

- Stainless Steel DynoMax VT® Muffler Assemblies
- 3.5-in. outlet, double wall, buffed and polished, 10-in. OAL SS slant cut tips
- 2.75-in. SS mandrel pipes

PART NUMBER 38504

**LIMITED LIFETIME WARRANTY +
90-DAY PERFORMANCE AND SOUND GUARANTEE***
on all systems



STAINLESS STEEL AXLE-BACK PERFORMANCE EXHAUST

2014-12 FORD MUSTANG BOSS 302 5.0L V8

2014-11 FORD MUSTANG GT 5.0L V8

2013-11 FORD MUSTANG SHELBY GT500 5.4L, 5.8L V8

- Stainless Steel Ultra Flo™ Welded Muffler Assemblies
- 3.5-in. outlet, double wall, buffed and polished, 10-in. OAL SS slant cut tips
- 2.75-in. SS mandrel pipes with O.E. spherical flare connection

PART NUMBER 39504

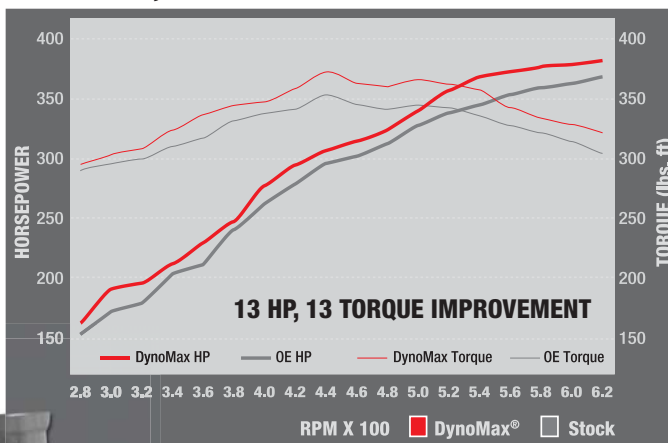

2010 FORD MUSTANG 4.0L V6

- Stainless Steel Ultra Flo™ Welded Muffler Assemblies
- 3.5-in. outlet, double wall, buffed and polished, 10-in. OAL SS slant cut tips
- 2.5-in. SS mandrel pipes

PART NUMBER 39488

**LIMITED LIFETIME WARRANTY +
90-DAY PERFORMANCE AND SOUND GUARANTEE*
on all systems**

**20 HORSEPOWER
18 LB-FT. TORQUE
IMPROVEMENT**



CAT-BACK SYSTEMS

2014-11 FORD MUSTANG 3.7L V6

- Stainless Steel Ultra Flo™ Welded Muffler Assemblies
- 3.5-in. outlet, double wall, buffed and polished, 10-in. OAL SS slant cut tips
- 2.5-in. SS mandrel pipes

PART NUMBER 39507

11 HORSEPOWER
10 LB-FT. TORQUE
IMPROVEMENT

2014-12 FORD MUSTANG BOSS 302 5.0L V8

2014-11 FORD MUSTANG GT 5.0L V8 2013-11 FORD MUSTANG SHELBY GT500 5.4L, 5.8L V8

- Stainless Steel Race Bullet Welded Muffler Assemblies
- 4-in. outlet, double wall, buffed and polished, 9-in. OAL SS slant cut tips
- 3-in. SS mandrel pipes

PART NUMBER 39505 (not shown)

16 HORSEPOWER
16 LB-FT. TORQUE
IMPROVEMENT

2010 FORD MUSTANG GT 4.6L V8 FORD MUSTANG SHELBY GT500 5.4L V8

- Stainless Steel Race Bullet Welded Muffler Assemblies
- 4-in. outlet, double wall, buffed and polished, 9-in. OAL SS slant cut tips
- 3-in. SS mandrel pipes

PART NUMBER 39489 (not shown)

21 HORSEPOWER
19 LB-FT. TORQUE
IMPROVEMENT

2010 FORD MUSTANG 4.0L V6

- Stainless Steel Ultra Flo™ Welded Muffler Assemblies
- 3.5-in. outlet, double wall, buffed and polished, 10-in. OAL SS slant cut tips
- 2.5-in. SS mandrel pipes

PART NUMBER 39503 (not shown)

15 HORSEPOWER
13 LB-FT. TORQUE
IMPROVEMENT

**LIMITED LIFETIME WARRANTY +
90-DAY PERFORMANCE AND SOUND GUARANTEE***
on all systems





STAINLESS STEEL CAT-BACK **DRONE-FREE PERFORMANCE EXHAUST**

**1992-83 CHEVROLET/PONTIAC CAMARO/FIREBIRD
2.8L, 3.1L, 5.0L V8 (EXC. H.O.)**

- Stainless Steel DynoMax VT® Muffler
- 3-in. outlet, single wall, buffed and polished, 6-in. OAL SS slant cut tips
- 2.5-in. SS mandrel pipes

PART NUMBER 38512



DRONE-FREE PERFORMANCE.™
MUFFLER

**LIMITED LIFETIME WARRANTY +
90-DAY PERFORMANCE AND SOUND GUARANTEE***
on all systems



STAINLESS STEEL DRONE-FREE PERFORMANCE EXHAUST

**1972-64 BUICK/CHEVROLET/OLDSMOBILE/PONTIAC
SKYLARK/GRAN SPORT/CHEVELLE/MALIBU/MONTE
CARLO/CUTLASS/442/GTO/LEMANS/TEMPEST ALL ENGINES V8**

- Stainless Steel DynoMax VT® Mufflers
- 3-in. outlet, single wall, buffed and polished, 6-in. OAL SS slant cut tips
- 2.5-in. SS mandrel pipes - designed to connect to long tube headers
- H-pipe included in system

PART NUMBER 38023



DRONE-FREE PERFORMANCE.™
MUFFLER

**LIMITED LIFETIME WARRANTY +
90-DAY PERFORMANCE AND SOUND GUARANTEE*
on all systems**



STAINLESS STEEL DRONE-FREE PERFORMANCE EXHAUST

**1972-70 DODGE/PLYMOUTH CHALLENGER/BARRACUDA
ALL ENGINES V8**

- Stainless Steel DynoMax VT® Mufflers
- 3-in. outlet, single wall, buffed and polished, 6-in. OAL SS slant cut tips
- 2.5-in. SS mandrel pipes - designed to connect to long tube headers
- H-pipe included in system

PART NUMBER 38026

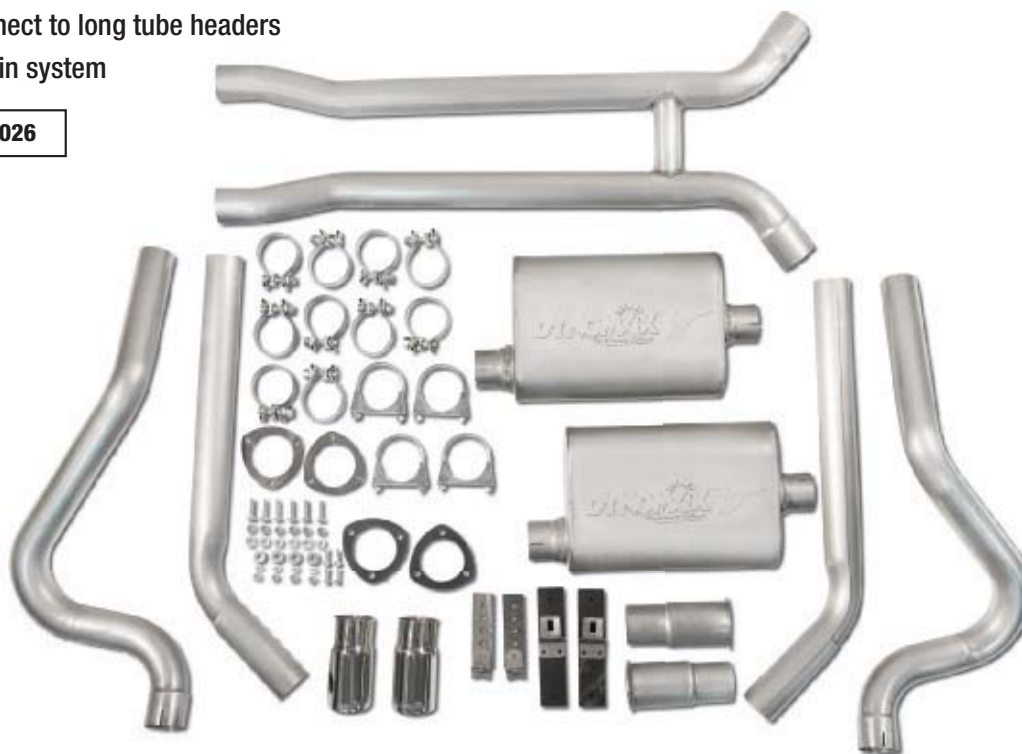

DRONE-FREE PERFORMANCE.™
MUFFLER

**LIMITED LIFETIME WARRANTY +
90-DAY PERFORMANCE AND SOUND GUARANTEE***
on all systems



STAINLESS STEEL DRONE-FREE PERFORMANCE EXHAUST

1970-67 FORD MUSTANG ALL ENGINES V8

- Stainless Steel DynoMax VT® Mufflers
- 3-in. outlet, single wall, buffed and polished, 6-in. OAL SS slant cut tips
- 2.5-in. SS mandrel pipes - designed to connect to long tube headers
- H-pipe included in system

PART NUMBER 38025

















DRONE-FREE PERFORMANCE.™
MUFFLER

LIMITED LIFETIME WARRANTY +
90-DAY PERFORMANCE AND SOUND GUARANTEE*
on all systems

Muscle Car Applications

BUICK

		ENGINE	PIPE DIA.	PART NO.	EXIT STYLE	SOUND LEVEL
Grand Sport						
1967-65	VT Header-Back	4.9L, 5.6L, 6.6L, 7.0L	2½"	38023 ^{SS} DynoMax VT	6	
GS, GS350, GS400						
1972-70	VT Header-Back	5.7L, 6.6L	2½"	38023 ^{SS} DynoMax VT	6	
Roadmaster						
1996-94	Cat-Back Sedan	5.7L	2½"	17375 Ultra Flo Polished	4	
Skylark						
1972-64	VT Header-Back	4.9L, 5.6L, 5.7L, 6.6L, 7.0L, 7.5L	2½"	38023 ^{SS} DynoMax VT	6	
CHEVROLET						
		ENGINE	PIPE DIA.	PART NO.	EXIT STYLE	SOUND LEVEL
Camaro						
2013-10	Axle-Back, Exc. Convertible	3.6L	2½"	39493 ^{SS} Ultra Flo Welded	4	
2013-10	Axle-Back,SS, Exc. Manual trans for 2011 model year; Exc. Convertible; Exc. Supercharged, ZL-1 Eng.	6.2L	2½"	39494 ^{SS} Ultra Flo Welded	4	
2013-10	Bullet Cat-Back, SS, Exc. Manual trans for 2011 model year; Exc. Convertible; Exc. Supercharged, ZL-1 Eng.; Aggressive Tone	6.2L	3"	39496 ^{SS} Ultra Flo Welded	4	
2013-10	VT Axle-Back, SS, Exc. Manual trans for 2011 model year; Exc. Convertible; Exc. Supercharged, ZL-1 Eng.	3.6L	2½"	38493 ^{SS} DynoMax VT	4	
2013-10	VT Axle-Back, SS, Exc. Manual trans for 2011 model year; Exc. Convertible; Exc. Supercharged, ZL-1 Eng.	6.2L	2½"	38494 ^{SS} DynoMax VT	4	
2002-98	Cat-Back	3.8L	3"	19396 Super Turbo	4	
2002-98	Cat-Back, Bullet Dual Exhaust	5.7L	3"	19418 Ultra Flo Welded	4	
2002-98	Cat-Back	5.7L	3"	17327 Super Turbo	4	
1992-90	Cat-Back	3.1L	2½"	17391 Ultra Flo Polished	4	
1992-90	Cat-Back	3.1L	2½"	17493 Super Turbo	4	
1992-83	VT Cat-Back	2.8L, 3.1L, 5.0L (H.O.)	2½"	38512 ^{SS} DynoMax VT	4	

Exit Style



^{SS} = Stainless Steel Construction

Sound Level



CHEVROLET (cont.)

		ENGINE	PIPE DIA.	PART NO.	EXIT STYLE	SOUND LEVEL
Camaro (cont.)						
1992-83	Cat-Back, Exc. H.O.; 2½" Connection to Cat. Conv.	5.0L	2½"	17391 Ultra Flo Polished	4	»»
1992-83	Cat-Back, Exc. H.O.; 2½" Connection to Cat. Conv.	5.0L	2½"	17493 Super Turbo	4	»»
1991-89	Cat-Back, FI & MFI Eng. Codes F & 8 w/Dual Catalysts	5.0L, 5.7L	2½"	17484 Super Turbo	4	»»
1991-86	Cat-Back, 4V High Output & EFI Eng. Code F & Code 8; 3" Flare w/Loose Flange Connection to Catalytic Converter; Exc. 91-89 Dual Catalysts	5.0L, 5.7L	2½"	17495 Super Turbo	4	»»
1989-83	Cat-Back	2.8L	2½"	17391 Ultra Flo SS	4	»»
1989-83	Cat-Back	2.8L	2½"	17493 Super Turbo	4	»»
1985-84	Cat-Back, Code G. Code F w/4 Bolt Inlet Flange Int. Pipe Connection	5.0L	2½"	17494 Super Turbo	4	»»
1981-77	Muffler-Back, Z-28, Early Models w/Mufflers Under Floor Pan	305, 350 C.I.D.	2"/2½"	17457 Super Turbo	4	»»»
Caprice						
1996-94	Cat-Back, Sedan	5.7L	2½"	17375 Ultra Flo SS	4	»»
Chevelle						
1972-64	VT Header-Back	4.6L, 5.0L, 5.3L, 5.4L, 5.7L, 6.5L, 6.6L, 7.4L	2½"	38023 ^{SS} DynoMax VT	6	»»»
Corvette						
2013-08	Cat-Back, LS3 ENG.; Exc. 2011-2009 ZR-1	6.2L	2½"	39462 ^{SS} Ultra Flo SS	12	»»»
2007-05	Cat-Back, LS2 Engine	6.0L	2½"	39462 ^{SS} Ultra Flo SS	12	»»»
1991-84	Cat-Back, Exc. ZR-1, Mufflers Only	5.7L	2½"	17483 Super Turbo	12	»»»
1982-74	Cat-Back, Mufflers Only	5.7L	2½"	17482 Super Turbo	4	»»»
1982	Cat-Back	5.7L	2½"	19467 Super Turbo	4	»»»
1981-78	Cat-Back	5.0L	2½"	19465 Super Turbo	4	»»»
1973-70	Cat-Back, Kit 72-70, Mufflers Only	5.7L, 7.4L	2½"	19470 Super Turbo	4	»»»

Exit Style



















^{SS} = Stainless Steel Construction

Sound Level



Muscle Car Applications

CHEVROLET (cont.)

		ENGINE	PIPE DIA.	PART NO.	EXIT STYLE	SOUND LEVEL
Impala						
2005-04	Cat-Back, SS, Supercharged	3.8L	2½"	19363 Super Turbo	4	
1996-94	Cat-Back, SS	5.7L	2½"	17375 Ultra Flo SS	4	
Malibu						
1967-65	VT Header-Back	4.6L, 5.4L, 6.5L	2½"	38023 ^{SS} DynoMax VT	6	
Monte Carlo						
2005-00	Cat-Back, SS, Inc. Supercharged	3.8L	2¼"/2½"	19363 Super Turbo	4	
1972-70	VT Header-Back	5.7L, 6.6L, 7.4L	2½"	38023 ^{SS} DynoMax VT	6	
CHRYSLER						
		ENGINE	PIPE DIA.	PART NO.	EXIT STYLE	SOUND LEVEL
300						
2013-11	Cat-Back	5.7L	2½"	39518 Super Turbo	4	
2013-12	Cat-Back	3.6L	2½"	39525 Super Turbo	4	
2010-05	Cat-Back	3.5L	2½"	19419 Super Turbo	4	
2010-05	Dual Exhaust	3.5L	2½"	19422 Super Turbo	4	
300c						
2010-06	Cat-Back, SRT8	6.1L	3"	38528 ^{SS} DynoMax VT	4	
2010-06	Cat-Back, SRT8, HEMI	6.1L	3"	19440 Ultra Flo Welded	4	
2010-05	Cat-Back, HEMI	5.7L	2½"	19412 Super Turbo	4	
2010-05	Cat-Back	5.7L	3"	38527 ^{SS} DynoMax VT	4	
DODGE						
		ENGINE	PIPE DIA.	PART NO.	EXIT STYLE	SOUND LEVEL
Challenger						
2013-09	Cat-Back, R/T	5.7L	3"	39490 ^{SS} Ultra Flo SS	4	
2010-08	Cat-Back, SRT8, HEMI	6.1L	3"	39484 ^{SS} Ultra Flo Welded	4	
2013-11	Cat-Back, SRT8	6.4L	3"	39484 ^{SS} Ultra Flo Welded	4	

Exit Style



^{SS} = Stainless Steel Construction

Sound Level

 Quiet - Loud

DODGE (cont.)

		ENGINE	PIPE DIA.	PART NO.	EXIT STYLE	SOUND LEVEL
Challenger cont.						
1972-70	VT Header-Back	5.2L, 5.6L, 5.9L, 6.3L, 6.6L, 7.0L, 7.2L	2½"	38026 ^{SS} DynoMax VT	4	
2013-09	VT Header-Back, R/T	5.7L	3"	38490 ^{SS} DynoMax VT	4	
2013-11	VT Header-Back, SRT8	6.4L	3"	38484 ^{SS} DynoMax VT	4	
2010-08	VT Header-Back, SRT8	6.1L	3"	38484 ^{SS} DynoMax VT	4	
Charger						
2010-06	Cat-Back, SRT8	6.1L	3"	38528 ^{SS} DynoMax VT	4	
2013-11	Cat-Back, R/T	5.7L	2½"	39518 Super Turbo	4	
2013-12	Cat-Back	3.6L	2½"	39525 Super Turbo	4	
2008-06	Cat-Back	3.5L	2½"	19419 Super Turbo	4	
2010-06	Cat-Back, Dual Exhaust	3.5L	2½"	19422 Super Turbo	4	
2008-06	Cat-Back, SRT8, HEMI	6.1L	3"	19440 Ultra Flo Welded	4	
2009-06	Cat-Back, R/T, HEMI	5.7L	2½"	19412 ^{SS} Super Turbo	4	
2010-06	Cat-Back, R/T	5.7L	3"	38527 ^{SS} DynoMax VT	4	
Magnum						
2009-06	Cat-Back, SRT8, HEMI	6.1L	3"	19440 Ultra Flo Welded	4	
2008-05	Cat-Back	3.5L	2½"	19419 Super Turbo	4	
2008-05	Cat-Back, Dual Exhaust	3.5L	2½"	19422 Super Turbo	4	
2008-05	Cat-Back, R/T, HEMI	5.7L	2½"	19412 Super Turbo	4	
2008-05	Cat-Back, R/T	5.7L	3"	38527 ^{SS} DynoMax VT	4	
FORD						
		ENGINE	PIPE DIA.	PART NO.	EXIT STYLE	SOUND LEVEL
Mustang						
2014-11	VT Axle-Back	3.7L	2¾"	38507 ^{SS} DynoMax VT	4	
2014-11	Axle-Back	3.7L	2½"	39507 ^{SS} Ultra Flo Welded	4	
2009-05	Cat-Back, Dual Exhaust	4.0L	2½"	39434 ^{SS} Ultra Flo Welded	4	

Exit Style



^{SS} = Stainless Steel Construction

Sound Level

Quiet - Loud

Muscle Car Applications

FORD (cont.)

		ENGINE	PIPE DIA.	PART NO.	EXIT STYLE	SOUND LEVEL
Mustang cont.						
2004-99	Cat-Back, Dual Exhaust	3.8L	2½"	19438 Super Turbo	4	➤
2010	Cat-Back, Dual Exhaust	4.0L	2½"	39503 ^{SS} Ultra Flo Welded	4	➤➤➤
2010	Cat-Back, Dual Exhaust	4.0L	2½"	38503 ^{SS} DynoMax VT	4	➤➤
1995-94	Polished Stainless Steel Rear Section	3.8L	2½"	17385 Ultra Flo SS	4	➤➤➤
2009-08	Cat-Back, Bullitt	4.6L	2½"	39414 ^{SS} Ultra Flo Welded	4	➤➤➤➤
2009-08	Cat-Back, Bullitt	4.6L	3"	39460 ^{SS} Ultra Flo Welded	4	➤➤➤➤➤
2001	Cat-Back, Bullitt	4.6L	2½"	19311 Ultra Flo SS	4	➤➤➤
2001	Cat-Back, Bullitt	4.6L	2½"	19485 Ultra Flo Welded	4	➤➤➤
2013-11	GT; Axle-Back	5.0L	2¾"	38504 ^{SS} DynoMax VT	4	➤➤
2009-05	Cat-Back, GT	4.6L	2½"	39414 ^{SS} Ultra Flo Welded	4	➤➤➤
2009-05	Cat-Back, GT, Bullet Mufflers	4.6L	3"	39460 ^{SS} Ultra Flo Welded	4	➤➤➤➤➤
1993-87	Cat-Back, GT, All Aluminized Steel Pipe Rear Section	5.0L	2½"	17394 Ultra Flo SS	4	➤➤➤
1993-87	Cat-Back, GT, All Aluminized Steel Pipe Rear Section	5.0L	2½"	17455 Super Turbo	4	➤➤
1993-87	Cat-Back, GT, All Aluminized Steel Pipe Rear Section	5.0L	2¼"	17490 Super Turbo	4	➤➤➤
1993-87	Cat-Back, GT, All Aluminized Steel Pipe Rear Section	5.0L	2½"	19482 Ultra Flo Welded	4	➤➤➤
1986	Cat-Back, GT, All Aluminized Steel Pipe Rear Section	5.0L	2¼"	17491 Super Turbo	4	➤➤➤
2010	GT, Axle-Back	4.6L	2½"	39488 ^{SS} Ultra Flo Welded	4	➤➤➤➤
2010	VT Cat-Back	4.6L	2½"	38488 ^{SS} DynoMax VT	4	➤➤
2004-99	Cat-Back, GT, SOHC	4.6L	2½"	19311 Ultra Flo SS	4	➤➤➤
2004-99	Cat-Back, GT, SOHC	4.6L	2½"	19485 Ultra Flo Welded	4	➤➤➤
2013-11	GT, Axle-Back	5.0L	2¾"	39504 ^{SS} Ultra Flo Welded	4	➤➤➤➤
2010	Cat-Back, GT, Bullet Cat-Back	4.6L	3"	39489 ^{SS} Ultra Flo Welded	4	➤➤➤➤➤

Exit Style



^{SS} = Stainless Steel Construction

Sound Level



FORD (cont.)

		ENGINE	PIPE DIA.	PART NO.	EXIT STYLE	SOUND LEVEL
Mustang cont.						
1986	Cat-Back, GT, Polished Stainless Steel Rear Section	5.0L	2½"	17393 Ultra Flo SS	4	➤➤➤
1986	Cat-Back, GT, Polished Stainless Steel Rear Section	5.0L	2½"	19483 Ultra Flo Welded	4	➤➤➤
2014-11	Cat-Back, GT, Race Bullet Exhaust System - Aggressive Tone	5.0L	3"	39505 ^{SS} Ultra Flo Welded	4	➤➤➤➤
1995-94	Cat-Back, GT, Cobra; Polished Stainless Steel Rear Section	5.0L	2½"	17385 Ultra Flo SS	4	➤➤➤
1970-67	VT Header-Back	4.7L, 5.0L 5.8L, 6.4L, 7.0L	2½"	38025 ^{SS} DynoMax VT	4	➤➤➤
1993-86	Cat-Back, LX, All Aluminized Steel Pipe Rear Section	5.0L	2¼"	17491 Super Turbo	4	➤➤➤
1993-86	LX, Polished Stainless Steel Rear Section	5.0L	2½"	17393 Ultra Flo SS	4	➤➤➤
1993-86	Cat-Back, LX, Polished Stainless Steel Rear Section	5.0L	2½"	19483 Ultra Flo Welded	4	➤➤➤
2004-03	Cat-Back, Mach 1	4.6L	2½"	19311 Ultra Flo SS	4	➤➤➤
2004-03	Cat-Back, Mach 1	4.6L	2½"	19485 Ultra Flo Welded	4	➤➤➤
2009-07	Cat-Back, Shelby GT	4.6L	2½"	19414 Ultra Flo Welded	4	➤➤➤
2009-07	Cat-Back, Shelby GT	4.6L	2½"	39414 ^{SS} Ultra Flo Welded	4	➤➤➤
2008-07	Cat-Back, Shelby GT	4.6L	3"	39460 ^{SS} Ultra Flo Welded	4	➤➤➤➤
2013	Shelby GT500, Axle-Back	5.8L	3"	38504 ^{SS} DynoMax VT	4	➤➤
2012-11	Shelby GT500; Axle-Back	5.4L	3"	38504 ^{SS} DynoMax VT	4	➤➤
2013-12	Boss 302, Axle-Back	5.0L	3"	38504 ^{SS} DynoMax VT	4	➤➤
2009-07	Cat-Back, Shelby GT500	5.4L	2½"	19414 Ultra Flo Welded	4	➤➤➤
2009-07	Cat-Back, Shelby GT500	5.4L	2½"	39414 ^{SS} Ultra Flo Welded	4	➤➤➤
2009-07	Cat-Back, Shelby GT500	5.4L	3"	39460 ^{SS} Ultra Flo Welded	4	➤➤➤➤
2013	Shelby GT500, Axle-Back	5.8L	3"	39504 ^{SS} DynoMax VT	4	➤➤
2012-11	Shelby GT500, Axle-Back	5.4L	3"	39504 ^{SS} Ultra Flo Welded	4	➤➤➤
2013-12	Boss 302, Axle-Back	5.0L	3"	39504 ^{SS} DynoMax VT	4	➤➤
2010	Cat-Back, Shelby GT500, Axle-Back	5.4L	2½"	39488 ^{SS} Ultra Flo Welded	4	➤➤➤
2010	Cat-Back, Shelby GT500, Bullet Cat-Back	4.6L	3"	39489 ^{SS} Ultra Flo Welded	4	➤➤➤➤
2013	Shelby GT500, Axle-Back	5.8L	3"	39505 ^{SS} DynoMax VT	4	➤➤

Exit Style















^{SS} = Stainless Steel Construction

Sound Level



Muscle Car Applications

FORD

		ENGINE	PIPE DIA.	PART NO.	EXIT STYLE	SOUND LEVEL
Mustang cont.						
2012-11	Cat-Back, Shelby GT500, Race Bullet Exhaust System - Aggressive Tone	5.4L	3"	39505 ^{SS} Ultra Flo Welded	4	
2014-12	Boss 302, Axle-Back	5.0L	3"	39505 ^{SS} DynoMax VT	4	
Taurus						
2012-10	Axle-BackSHO, OE rear dual mufflers must be cut-off the OE welded assy. Eco Boost	3.5L	2¼"	39502 ^{SS} Ultra Flo Welded	12	
1995-93	Cat-Back, SHO, w/Auto. Trans.	3.2L	2¼"	17399 Super Turbo	3	
1995-92	Cat-Back, SHO, w/Man. Trans.	3.0L	2¼"	17400 Super Turbo	4	
Thunderbird						
1997-92	Cat-Back	4.6L, 5.0L	2¼"	17379 Super Turbo	4	
LINCOLN						
MKS						
2012-10	Axle-Back, OE rear dual mufflers must be cut-off the OE welded assy. Eco Boost	3.5L	2¼"	39502 ^{SS} Ultra Flo Welded	12	
MERCURY						
		ENGINE	PIPE DIA.	PART NO.	EXIT STYLE	SOUND LEVEL
Capri						
1986	Cat-Back, All Aluminized Steel Pipe Rear Section	5.0L	2¼"	17491 Super Turbo	4	
1986	Cat-Back, Polished Stainless Steel Rear Section	5.0L	2½"	17393 Ultra Flo SS	4	
1993-86	Cat-Back, Polished Stainless Steel Rear Section	5.0L	2½"	19483 Ultra Flo Welded	4	
Cougar						
1997-92	Cat-Back	4.6L, 5.0L	2¼"	17379 Super Turbo	4	
OLDSMOBILE						
		ENGINE	PIPE DIA.	PART NO.	EXIT STYLE	SOUND LEVEL
442						
1972-64	VT Header-Back	5.4L, 5.7L, 6.6L, 7.5L	2½"	38023 ^{SS} DynoMax VT	6	

Exit Style



^{SS} = Stainless Steel Construction

Sound Level

 Quiet - Loud

OLDSMOBILE

		ENGINE	PIPE DIA.	PART NO.	EXIT STYLE	SOUND LEVEL
Cutlass						
1971-64	VT Header-Back	5.4L, 5.7L, 6.6L, 7.5L	2½"	38023 ^{SS} DynoMax VT	6	➤➤➤
Barracuda						
1972-70	VT Header-Back	5.2L, 5.6L, 5.9L, 6.3L, 7.0L, 7.2L	2½"	38026 ^{SS} DynoMax VT	4	➤➤➤
PONTIAC						
Firebird						
2002-98	Cat-Back, Dual Outlet Muffler	3.8L	3"	19396 Super Turbo	4	➤➤
2002-98	Cat-Back, Dual Outlet Muffler	5.7L	3"	17327 Super Turbo	4	➤➤➤
2002-98	Cat-Back, Trans AM, Bullet Dual Exhaust	5.7L	3"	19418 Ultra Flo Welded	4	➤➤➤➤
1992-90	Cat-Back	3.1L	2½"	17391 Ultra Flo SS	4	➤➤➤
1992-90	Cat-Back	3.1L	2½"	17493 Super Turbo	4	➤➤
1992-83	VT, Cat-Back	2.8L, 3.1L	2½"	38512 ^{SS} DynoMax VT	4	➤➤
1992-83	VT, Cat-Back	5.0L (H.O.)	2½"	38512 ^{SS} DynoMax VT	4	➤➤
1992-83	Cat-Back, Exc. H.O.; 2½" Flare Connection to Cat. Converter	5.0L	2½"	17391 Ultra Flo SS	4	➤➤➤
1992-83	Cat-Back, Exc. H.O.; 2½" Flare Connection to Cat. Converter	5.0L	2½"	17493 Super Turbo	4	➤➤
1991-89	Cat-Back, FI & MFI Eng. Codes F & 8 w/Dual Catalysts	5.0L, 5.7L	2½"	17484 Super Turbo	4	➤➤
1991-86	Cat-Back, 4V High Output & EFI Eng. Code F & Code 8; 3" Flare w/Loose Flange Connection to Catalytic Converter; Exc. 91 -89 Dual Catalysts	5.0L, 5.7L	2½"	17495 Super Turbo	4	➤➤
1989-83	Cat-Back	2.8L	2½"	17391 Ultra Flo SS	4	➤➤➤
1989-83	Cat-Back	2.8L	2½"	17493 Super Turbo	4	➤➤
1985-84	Cat-Back, Code G; Code F w/4 Bolt Inlet Flange Int. Pipe Connection	5.0L, 5.7L	2½"	17494 Super Turbo	4	➤➤
1981-78	Muffler-Back, Early Models w/Mufflers Under Floor Pan	301, 305, 400, 403 C.I.D.	2"/2½"	17457 Super Turbo	4	➤➤➤
Grand Prix						
2005-97	Cat-Back, GTP	3.8L	2¼"/2½"	19363 Super Turbo	4	➤➤➤
2004-03	Cat-Back, GT	3.8L	2¼"/2½"	19363 Super Turbo	4	➤➤➤

Exit Style



^{SS} = Stainless Steel Construction

Sound Level

 Quiet - Loud

Muscle Car Applications

PONTIAC (cont.)

		ENGINE	PIPE DIA.	PART NO.	EXIT STYLE	SOUND LEVEL
Grand Prix cont.						
1998-97	Cat-Back, GT	3.8L	2¼"/2½"	19363 Super Turbo	4	
2005	Cat-Back, GXP	5.3L	2¼"/2½"	19363 Super Turbo	4	
GTO						
1972-64	VT Header-Back	5.3L, 5.7L, 6.4L, 6.6L, 6.9L, 7.0L, 7.5L	2½"	38023 ^{SS} DynoMax VT	6	
Lemans						
1972-64	VT, Header-Back	5.3L, 5.7L, 6.4L, 6.6L, 7.0L, 7.5L	2½"	38023 ^{SS} DynoMax VT	6	
Solstice						
2009-06	Cat-Back, DOHC	2.4L	2½"	39435 ^{SS} Ultra Flo SS	5	
Tempest						
1972-64	VT, Header-Back	5.3L, 5.7L, 6.4L, 6.6L, 7.0L, 7.5L	2½"	38023 ^{SS} DynoMax VT	6	
SATURN						
Sky						
2009-07	Cat-Back, DOHC	2.4L	2½"	39435 ^{SS} Ultra Flo SS	5	

Exit Style



^{SS} = Stainless Steel Construction

Sound Level



Quiet - Loud