



THRUSH® MAD HOT

TRI-FLOW TECHNOLOGY

Fully Aluminized construction for long life
 High gloss red powder coat finish
 Thrush Logo embossed on muffler cover
 Available in 2.25-in., 2.5-in., or 3-in. inlet and outlet
 Reversible for maximum flexibility



HUSH THRUSH™

TRI-FLOW TECHNOLOGY

Fully Aluminized construction for long life
 Fiberglass matting for better sound control
 Thrush Logo embossed on muffler cover
 Available in 2.25-in., 2.5-in., or 3-in. inlet and outlet
 Reversible for maximum flexibility

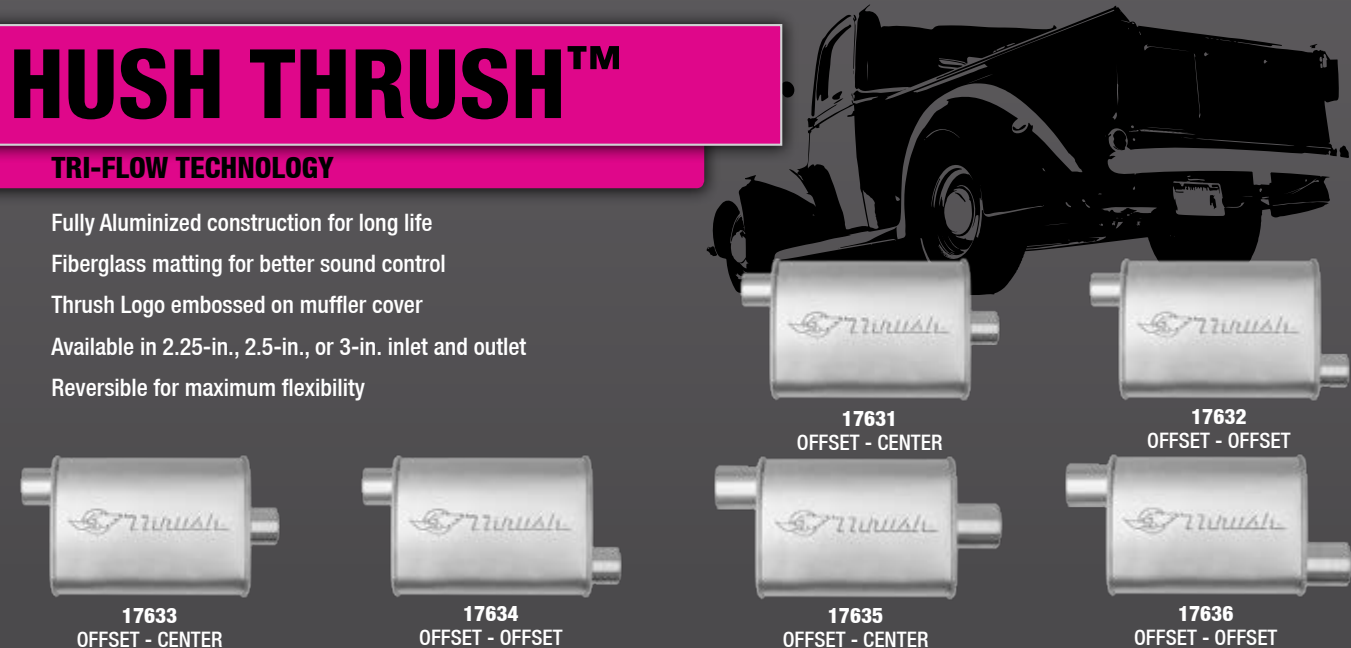

Application Chart

PART NO.	CONFIGURATION	SHELL LENGTH	OVERALL LENGTH	SHELL DIAMETER	INLET DIAMETER	OUTLET DIAMETER
17931	Offset - Center	14	18.5	4.25 x 9.75	2.25	2.25
17932	Offset - Offset	14	18.5	4.25 x 9.75	2.25	2.25
17933	Offset - Center	14	18.5	4.25 x 9.75	2.5	2.5
17934	Offset - Offset	14	18.5	4.25 x 9.75	2.5	2.5
17935	Offset - Center	14	20	4.25 x 9.75	3.0	3.0
17936	Offset - Offset	14	20	4.25 x 9.75	3.0	3.0

Application Chart

PART NO.	CONFIGURATION	SHELL LENGTH	OVERALL LENGTH	SHELL DIAMETER	INLET DIAMETER	OUTLET DIAMETER
17631	Offset - Center	14	18.5	4.25 x 9.75	2.25	2.25
17632	Offset - Offset	14	18.5	4.25 x 9.75	2.25	2.25
17633	Offset - Center	14	18.5	4.25 x 9.75	2.5	2.5
17634	Offset - Offset	14	18.5	4.25 x 9.75	2.5	2.5
17635	Offset - Center	14	20	4.25 x 9.75	3.0	3.0
17636	Offset - Offset	14	20	4.25 x 9.75	3.0	3.0

All measurements are in inches. Configuration is shown as inlet - outlet. Shell diameter is shown as height x width. Inlet/outlet diameter is ID.

All measurements are in inches. Configuration is shown as inlet - outlet. Shell diameter is shown as height x width. Inlet/outlet diameter is ID.

VINTAGE SOUND...TODAY'S POWER™



THRUSH® TURBO

TRI-FLOW TECHNOLOGY

Tri-flow design provides that Thrush® classic sound
 100-percent Aluminized coated shell for long life
 Available in 2-in., 2.25-in. or 2.5-in. inlet and outlet
 Reversible for maximum flexibility

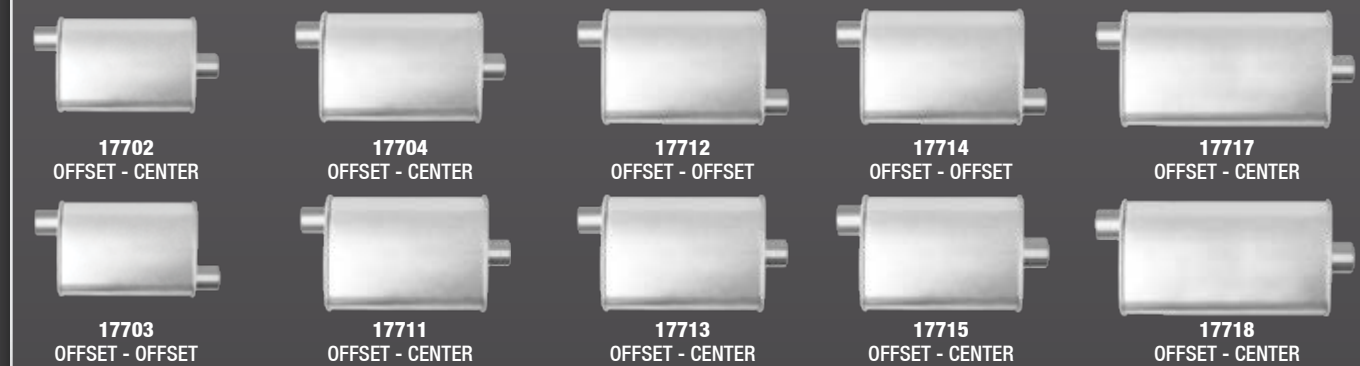

THRUSH® WELDED

TWO CHAMBER TECHNOLOGY

100-percent Welded construction for durability and extended life
 Thrush Logo embossed on muffler cover
 Available in 2.25-in., 2.5-in. or 3-in. inlet and outlet



Application Chart

PART NO.	CONFIGURATION	SHELL LENGTH	OVERALL LENGTH	SHELL DIAMETER	INLET DIAMETER	OUTLET DIAMETER
17654	Dual Offset - Dual Offset	20	24	4.25 x 9.75	2.5 (2)	2.5 (2)
17696	Offset - Offset	14	18.5	4.25 x 9.75	2.5	2.5
17702	Offset - Center	11	16	3.25 x 7.75	2.0	2.0
17703	Offset - Offset	11	16	3.25 x 7.75	2.0	2.0
17704	Offset - Center	14	18.5	3.25 x 7.75	2.0	2.0
17711	Offset - Center	14	18.5	4.25 x 9.75	2.0	2.0
17712	Offset - Offset	14	18.5	4.25 x 9.75	2.0	2.0
17713	Offset - Center	14	18.5	4.25 x 9.75	2.25	2.25
17714	Offset - Offset	14	18.5	4.25 x 9.75	2.25	2.25
17715	Offset - Center	14	18.5	4.25 x 9.75	2.5	2.5
17717	Offset - Center	20	25	4.25 x 9.75	2.25	2.25
17718	Offset - Center	20	25	4.25 x 9.75	2.5	2.5

All measurements are in inches. Configuration is shown as inlet - outlet. Shell diameter is shown as height x width. Inlet/outlet diameter is ID.

Application Chart

PART NO.	CONFIGURATION	SHELL LENGTH	OVERALL LENGTH	SHELL DIAMETER	INLET DIAMETER	OUTLET DIAMETER
17630	Center - Dual Offset	13	19	4.00 x 9.50	3.0	2.25 (2)
17637	Dual Offset - Dual Offset	17	23	4.00 x 9.50	2.25 (2)	2.25 (2)
17638	Offset - Dual Offset	15	21	4.00 x 9.50	2.5	2.5 (2)
17649	Center - Offset	13	19	4.00 x 9.50	3.0	3.0
17650	Center - Offset	13	19	4.00 x 9.50	2.5	2.5
17651	Center - Offset	13	19	4.00 x 9.50	2.25	2.25
17652	Center - Dual Offset	13	19	4.00 x 9.50	2.25	2.25 (2)
17653	Center - Dual Offset	13	19	4.00 x 9.50	2.5	2.5 (2)
17655	Offset - Center	13	19	4.00 x 9.50	2.25	2.25
17656	Offset - Center	13	19	4.00 x 9.50	2.5	2.5
17657	Offset - Center	13	19	4.00 x 9.50	3.0	3.0
17658	Offset - Offset	13	19	4.00 x 9.50	2.25	2.25
17659	Offset - Offset	13	19	4.00 x 9.50	2.5	2.5
17660	Offset - Offset	13	19	4.00 x 9.50	3.0	3.0
17661	Center - Dual Offset	13	19	4.00 x 9.50	3.0	2.5 (2)

All measurements are in inches. Configuration is shown as inlet - outlet. Shell diameter is shown as height x width. Inlet/outlet diameter is ID.

VINTAGE SOUND...TODAY'S POWER™

THRUSH EXHAUST.COM

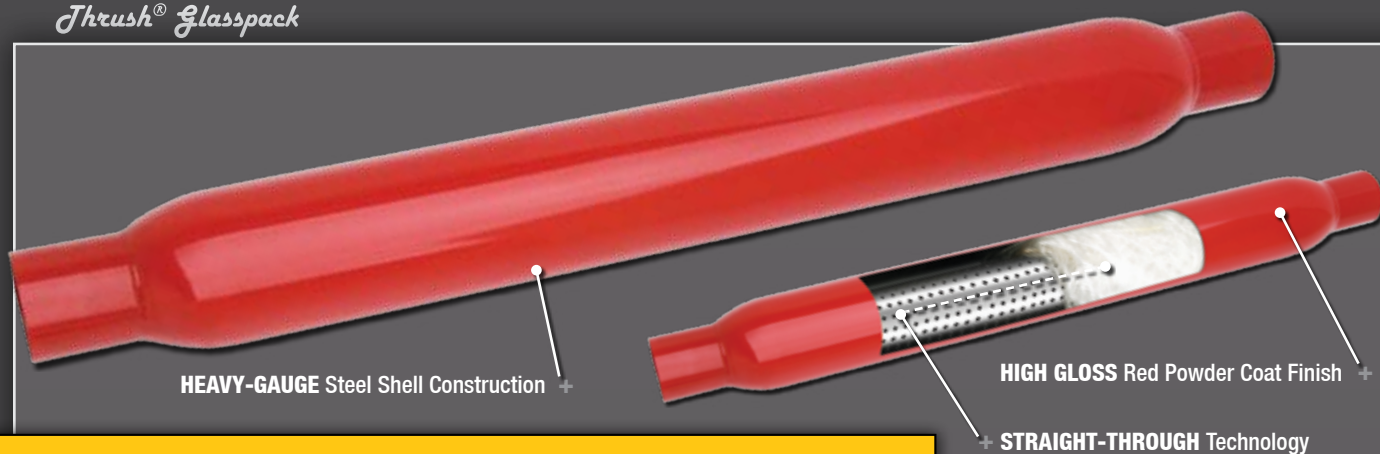

THRUSH® GLASSPACK

STRAIGHT-THROUGH TECHNOLOGY

Straight-through design for maximum flow and power

Heavy-gauge steel shell construction

Available in 1.75-in., 2-in., 2.25-in., 2.5-in., or 3-in. inlet and outlet

High Gloss Red Powder Coat Finish or 304 Polished Stainless Steel

Dual outlet models available

Application Chart

SINGLE AND DUAL OUTLET - RED POWDER COAT FINISH

PART NO.	CONFIGURATION	SHELL LENGTH	OVERALL LENGTH	SHELL DIAMETER	INLET DIAMETER	OUTLET DIAMETER
24069	Center - Center	18	23	3.5	2.25	2.25
24200	Center - Center	20	25	3.5	2.0	2.0
24201	Center - Center	20	25	3.5	2.25	2.25
24202	Center - Center	22	27	3.5	2.0	2.0
24203	Center - Center	22	27	3.5	2.25	2.25
24204	Center - Center	26	31	3.5	2.0	2.0
24205	Center - Center	26	31	3.5	2.25	2.25
24210	Center - Center	12	17	3.0	1.75	1.75
24214	Center - Center	23	28	4.0	2.5	2.5
24224 ¹	Center - Dual	18	29	4.0	3.0	2.5 (2)
24242	Center - Center	20	25	4.0	3.0	3.0

SINGLE OUTLET - 304 POLISHED STAINLESS STEEL FINISH

PART NO.	CONFIGURATION	SHELL LENGTH	OVERALL LENGTH	SHELL DIAMETER	INLET DIAMETER	OUTLET DIAMETER
24240	Center - Center	20	25	3.5	2.5	2.5
24241	Center - Center	20	25	4.0	3.0	3.0

HEADER GLASSPACK MUFFLER

PART NO.	A	B	C	D	BODY DIAMETER	USE GASKET NO.
24221 ²	4.25	3.40625	3.9375	3.0	4.0	88201

HEADER GLASSPACK MUFFLER WITH TURN DOWN

PART NO.	A	B	C	D	BODY DIAMETER	USE GASKET NO.
24223	4.25	3.40625	3.9375	3.0	4.0	88201

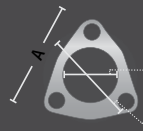
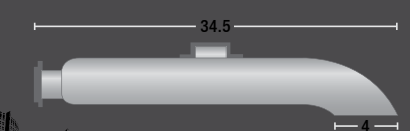
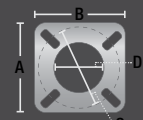
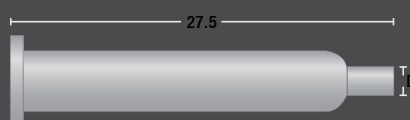

All measurements are in inches. Configuration is shown as inlet - outlet. Inlet/outlet diameter is ID. ¹ Fully reversible. ² Fits with 3-in. header collector.

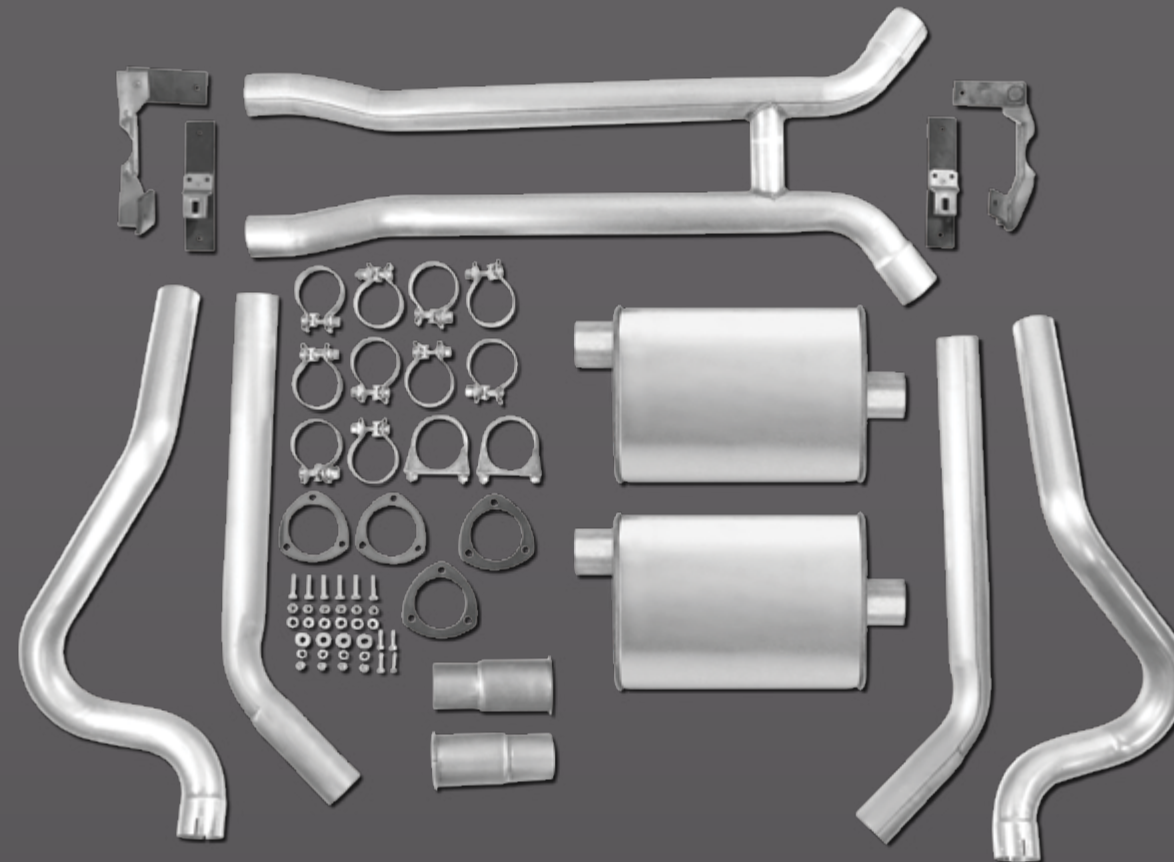

THRUSH® TURBO HEADER BACK SYSTEMS

Available for vintage muscle cars and trucks

Thrush® Turbo Mufflers are included in the system

Most systems feature 2.5-in. Aluminized smooth bend pipes

H-pipe balance tube is included in the system

All accessories needed for installation are included



Application Chart

YEAR	MODEL	ENGINE	PART NO.
72-64	Skylark	265-454CH	89023
74-67	Camaro - Exc. convertible	265-454	89021
72-64	Chevelle	265-454	89023
67-64	Malibu	265-454	89023
72-70	Monte Carlo	265-454	89023
74-67	Nova	265-454	89021
70-67	Mustang	289-302	89025
70-68	Mustang	427-429	89025
70-69	Mustang	351W	89025
1970	Mustang	351C-2V	89025
1970	Mustang	351C-4V	89025
69-67	Mustang	390	89025

YEAR	MODEL	ENGINE	PART NO.
72-65	Cutlass	350-455OL	89023
72-64	Cutlass	265-454CH	89023
74-70	Firebird - Exc. convertible	326-455PO	89021
74-67	Firebird - Exc. convertible	265-454CH	89021
72-64	GTO, LeMans, Tempest	265-454CH	89023

CHEVROLET/GMC C-SERIES PICKUP - 2WD

YEAR	MODEL	ENGINE	PART NO.
72-66	1/2, 3/4 Ton Pickup	283-350	89027 ³
72-68	1/2, 3/4 Ton Pickup	396-454	89027 ³

CHEVROLET/GMC K-SERIES PICKUP - 4WD

YEAR	MODEL	ENGINE	PART NO.
87-73	1/2, 3/4, 1 Ton Pickup	350-454	89024 ⁴

³ Fits with rear coil springs only. ⁴ Kit pipes are 2.25-in. O.D. CH - Chevrolet. OL - Oldsmobile. PO - Pontiac.

VINTAGE SOUND...TODAY'S POWER™